



NORTALU[®]

www.nortalu.pt

SÉRIE PT





SÉRIE PT

Sistema PT permite fazer portões com vários modelos tanto na opção de abrir como de correr. Esta série apresenta perfis para uma solução tradicional permitindo o uso de perfis para soldar, como uma solução totalmente aperfeiçoada de forma aligeirar o processo de fabricação. Os portões de alumínio são uma excelente solução para o exterior, devido a estarem permanentemente expostos às diversas agressões climatéricas. Permitindo uma cor uniforme com a caixilharia por receber exatamente o mesmo tratamento, mantendo a mesma cor e longevidade.

Soluções Construtivas:

- Portões Abrir e Correr

Vedantes:

- Material em EPDM ou PVC em conformidade com a norma aplicável.

Acessórios:

- Materiais em alumínio, zamac, aço inox e nylon em conformidade com a norma aplicável.



Versão PT Soldar

PT.02 *Aro Fixo (Sistema de Abrir)*

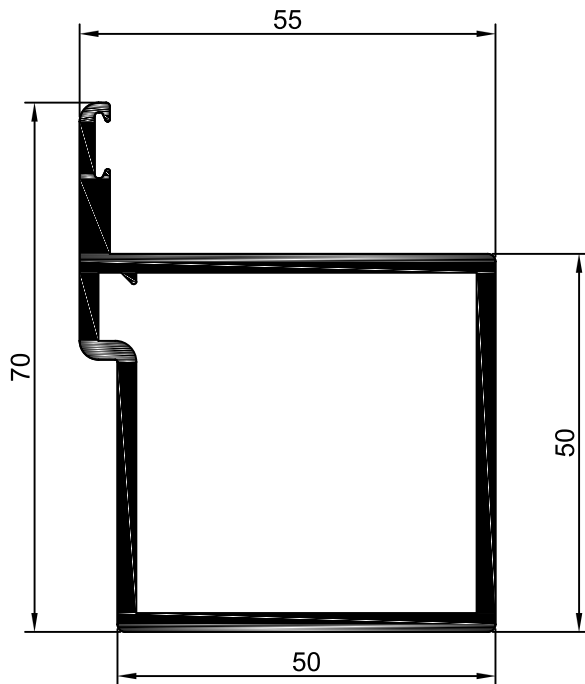

PT.01 *Aro Móvel (Sistema de Abrir e Correr)*

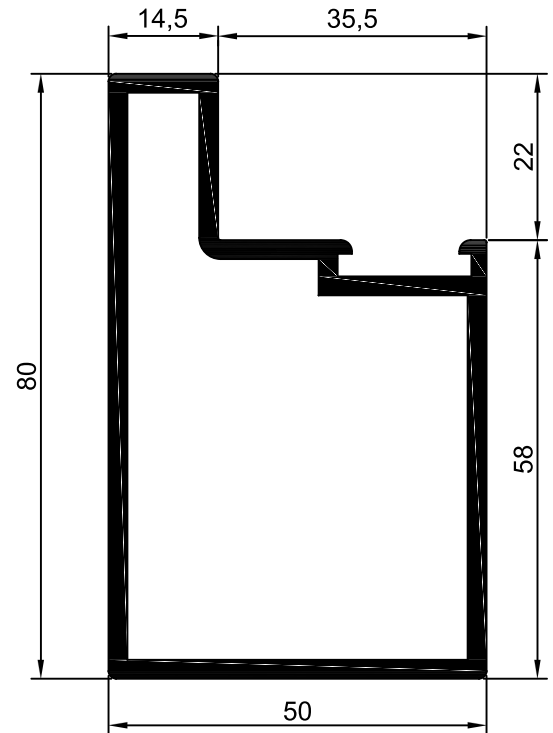

PT.03 *Travessa*

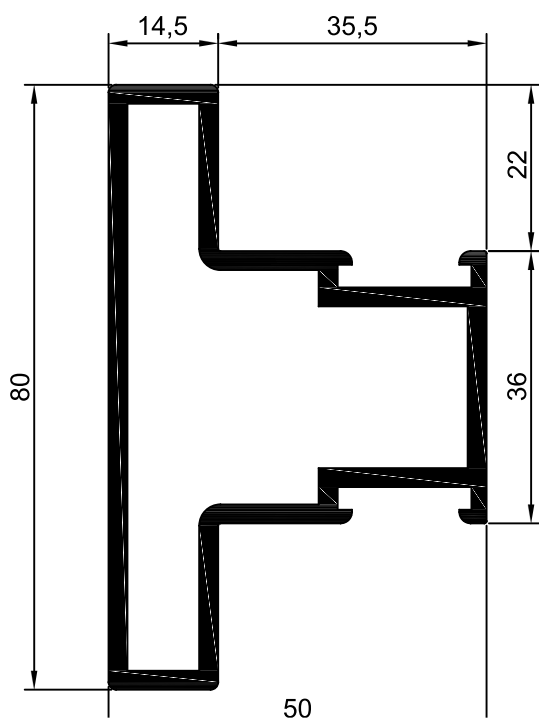

PT.04 *Inversor (Sistema de Abrir)*

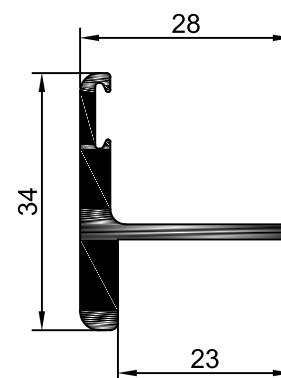

PT.104 Aro Móvel (Sistema de Abrir)

Versão PT Soldar

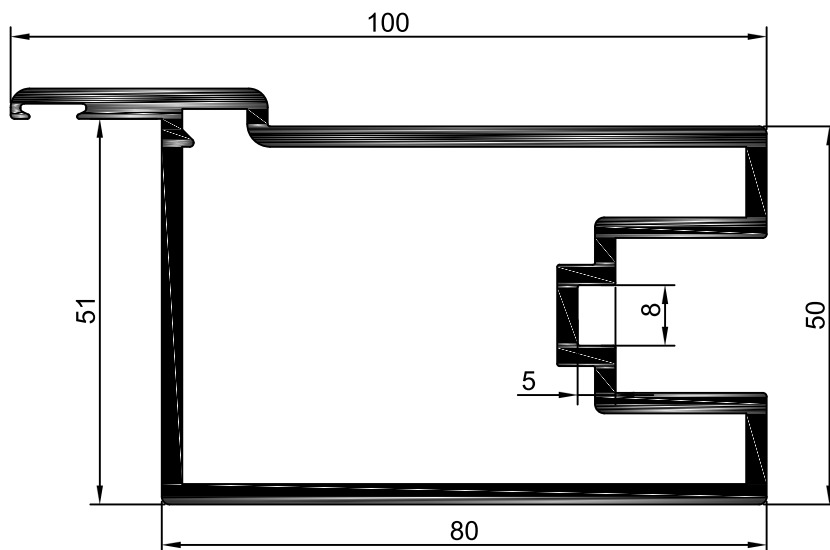

PT.103 Travessa

PT.101 Aro Móvel (Sistema de Abrir e Correr)

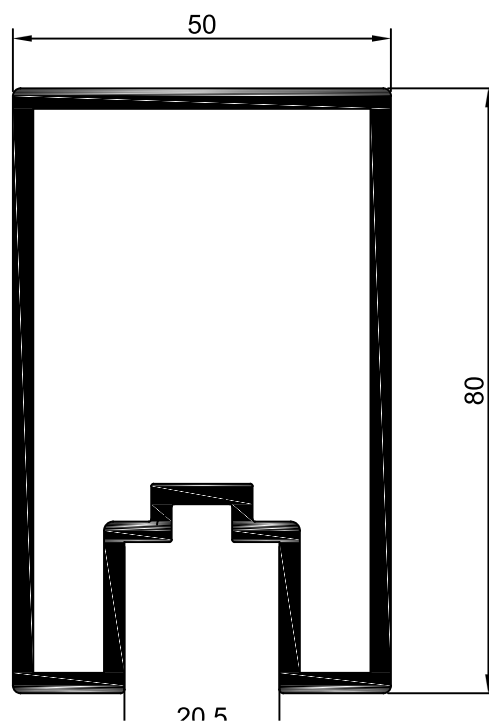
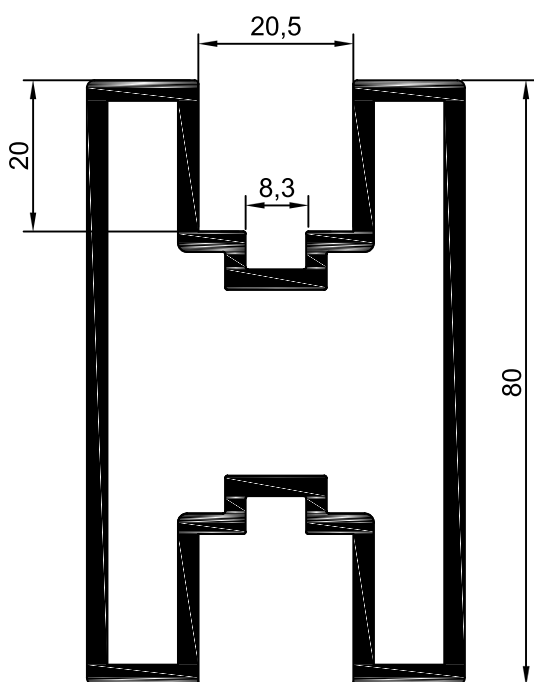

PT.105 *Prumo Vertical*

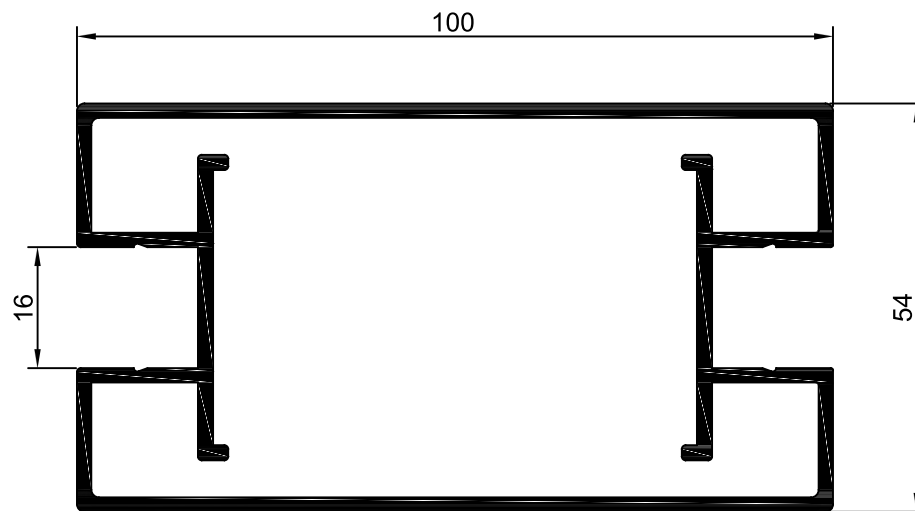

PT.106 *Travessa Superior/Inferior*

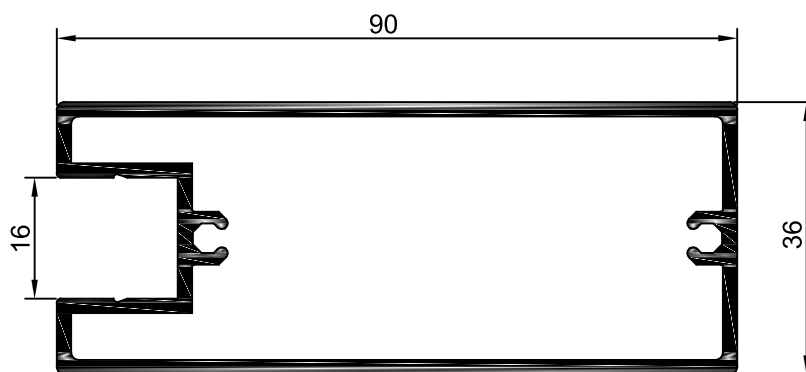

PT.107 *Travessa Central*

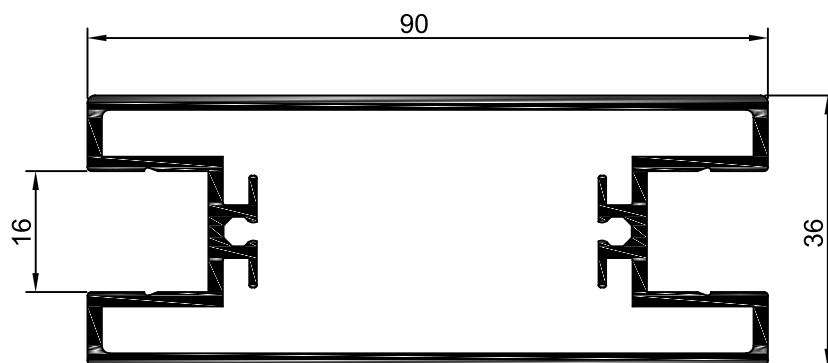

P.24 Régua

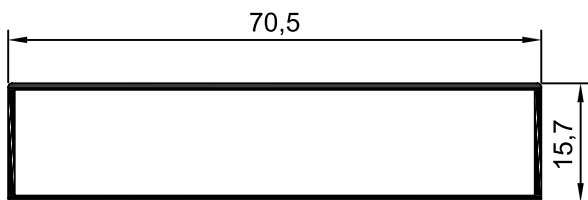

PT.109A Tapa Junta

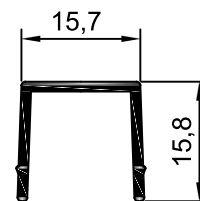

PT.109 Redutor

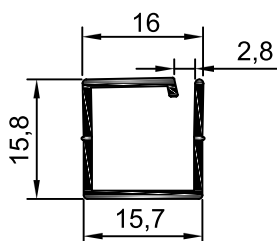

PT.123 Rail Portão Correr

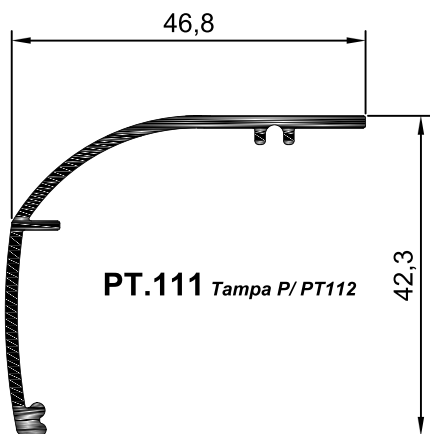
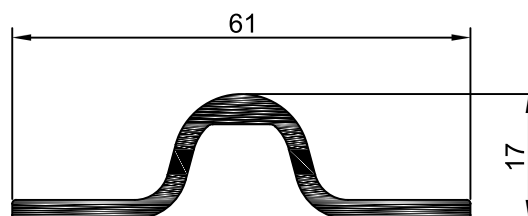

PT.111 Tampa P/ PT112

PT.108 Inversor

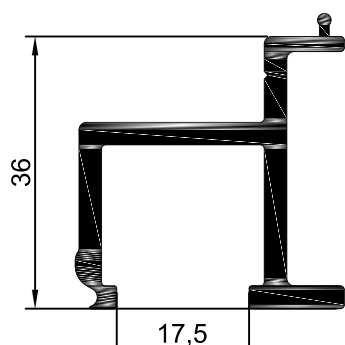
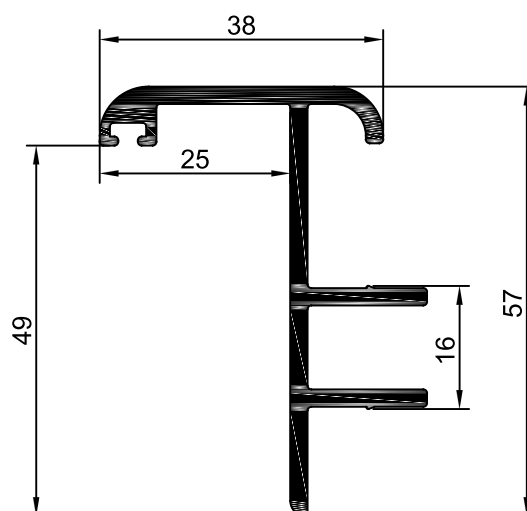

PT.112 Callha Lateral

PT.15 *Perfil Poste*

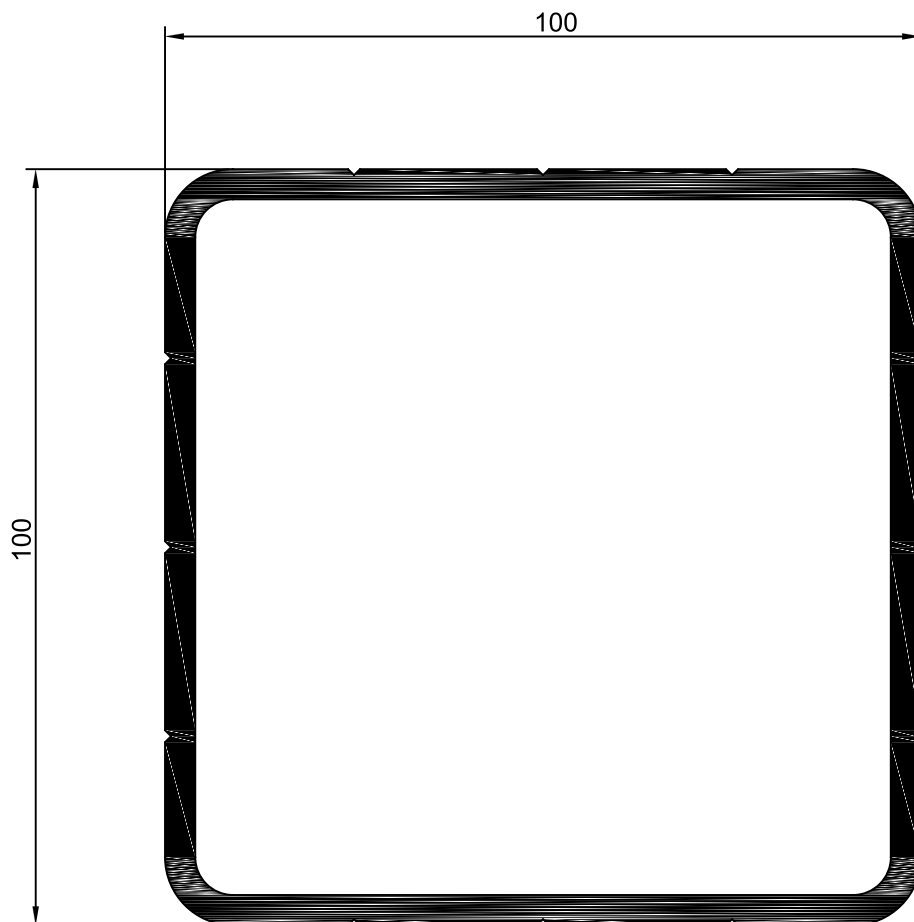

PT.15A *Tampa PT.15*

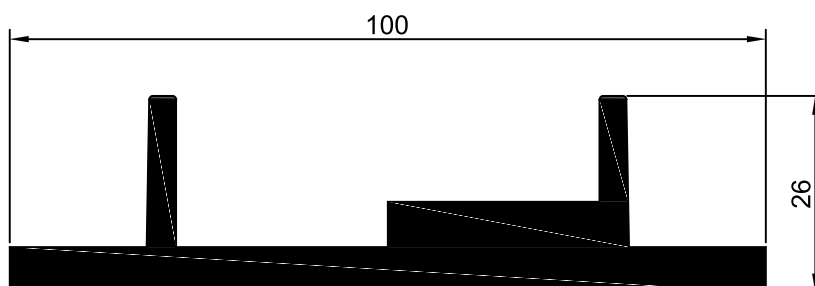

Q.21 Perfil Poste

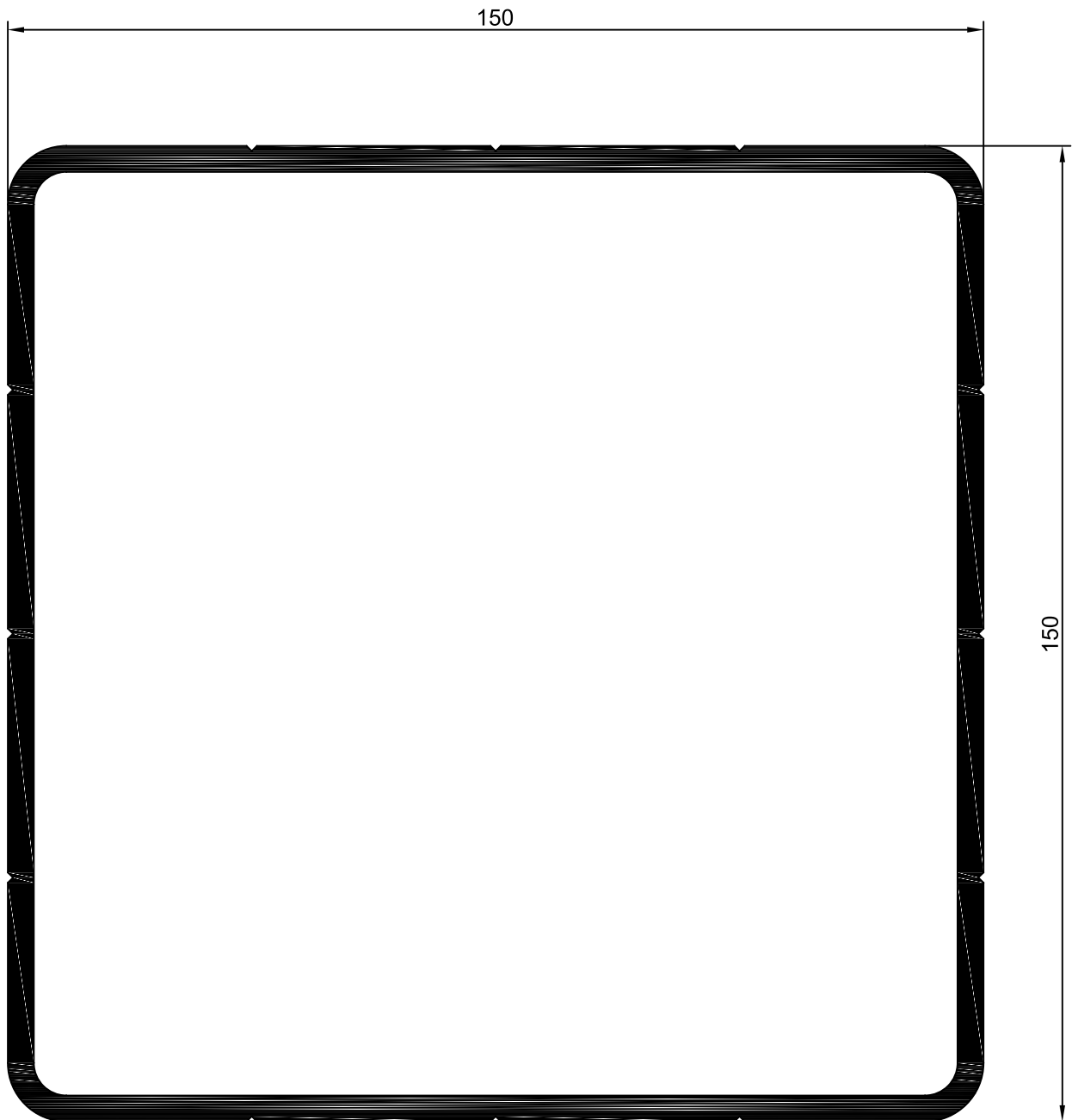

PT.231 *Prumo Vertical*

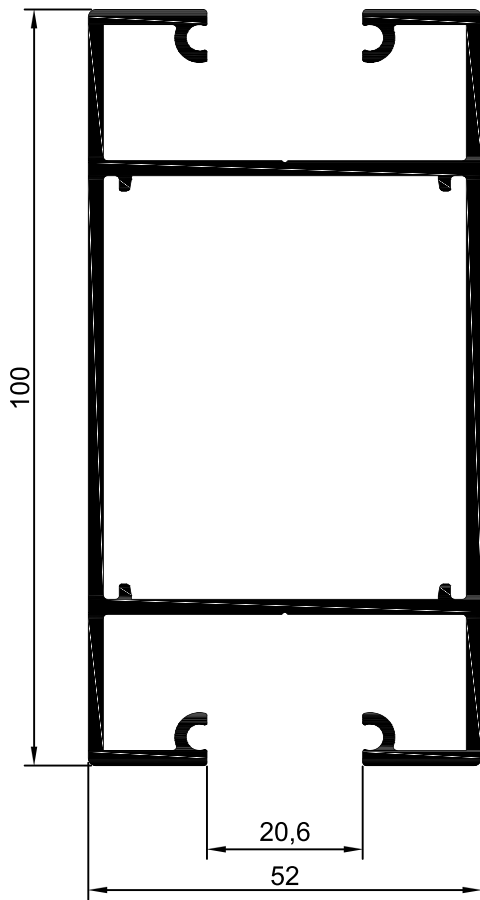

B.34 *Barra Maciça*

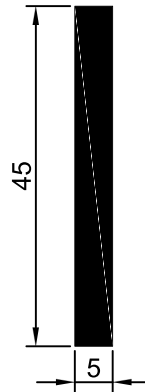

PT.233 *Travessa Central*

Versão PT Plus

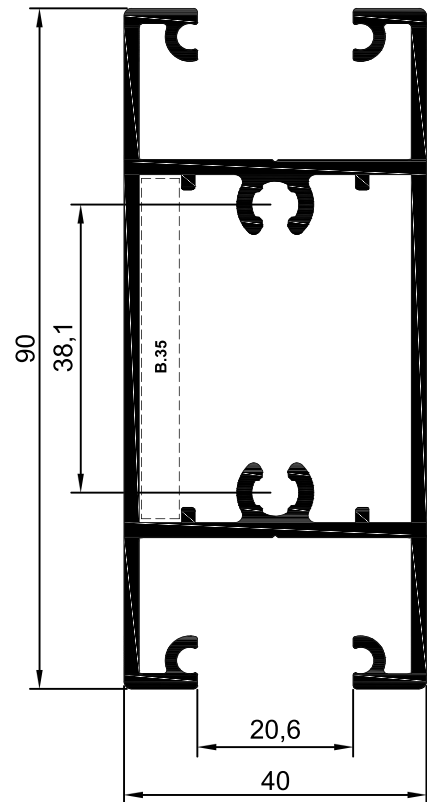

PT.253 *Bite Redutor*

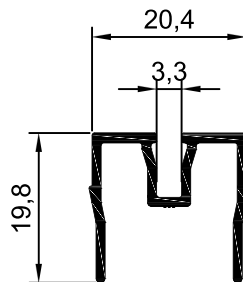

PT.241 *Prumo Vertical*

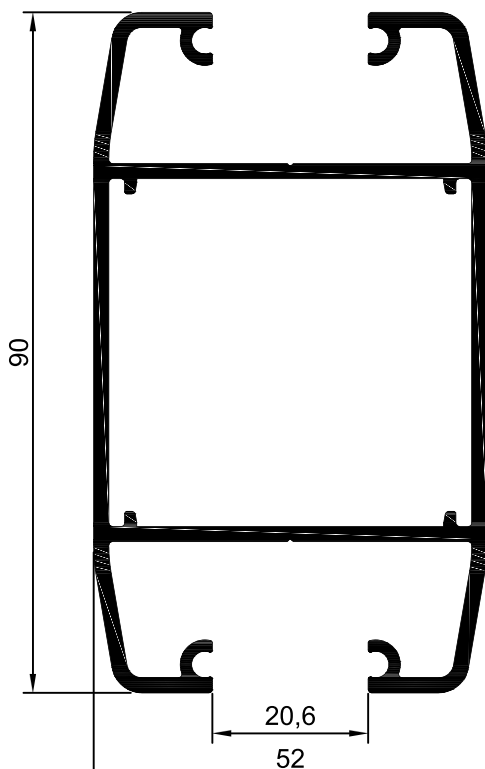

PT.242 *Travessa Central*

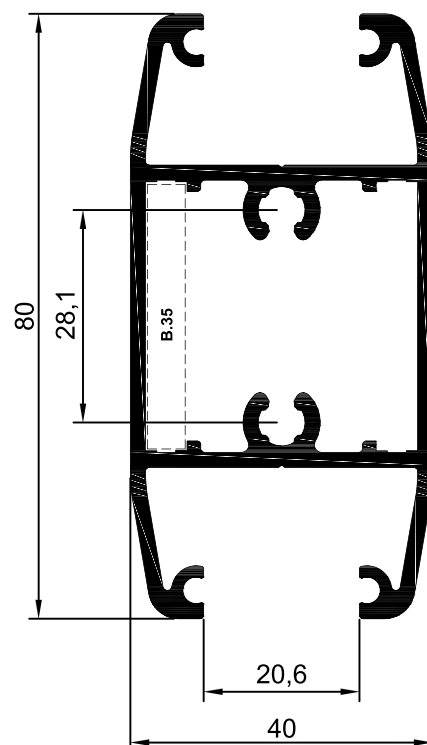

B.35 *Barra Maciça*

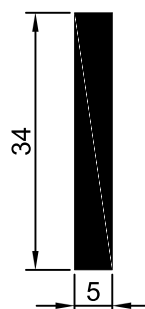

PT.234 Travessa Superior / Inferior

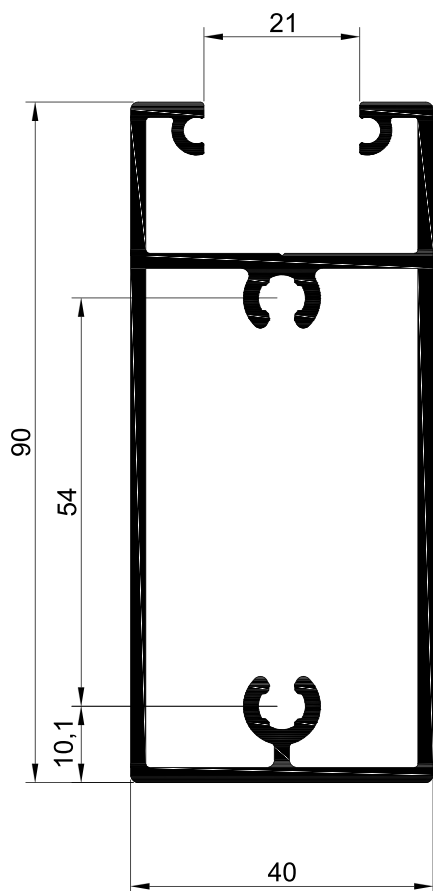

PT.236 Travessa Central

Versão PT Plus

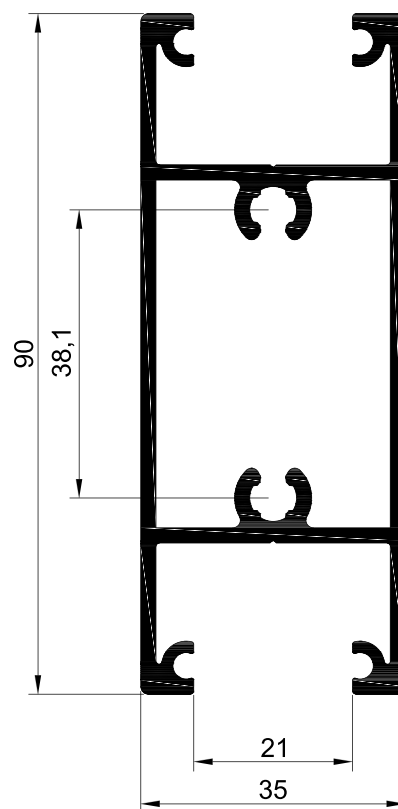

PT.235 Travessa Central

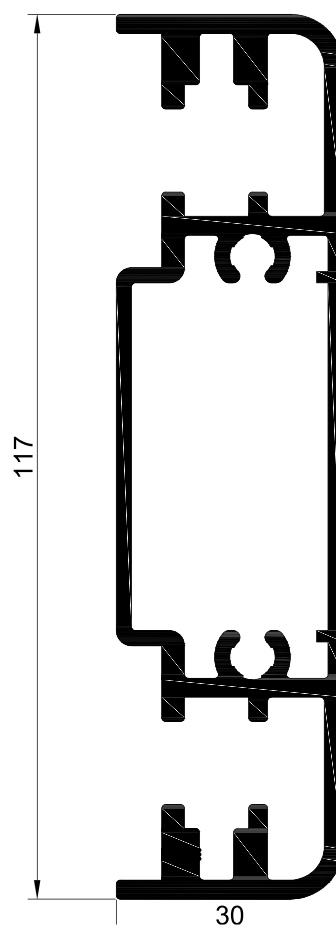
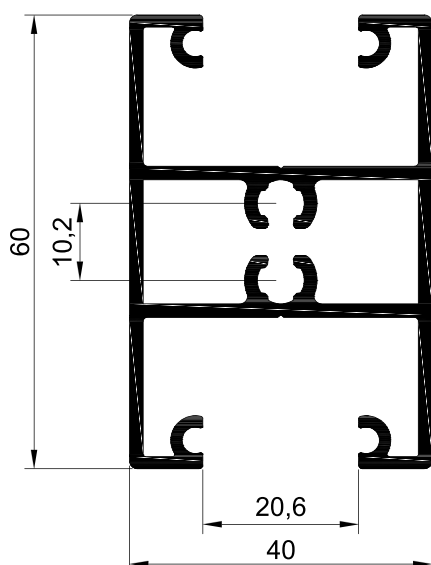

PT.226 Prumo para Guias

PT.261 Prumo Vertical (Grades)

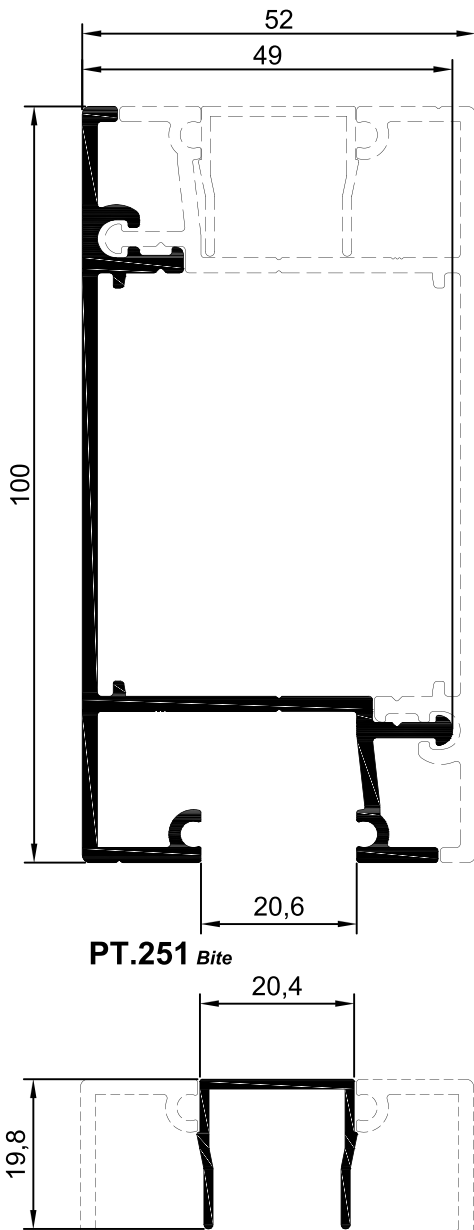

U.29 Calha "U"

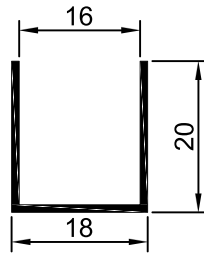

PT.230 Aro Fixo

Versão PT Plus

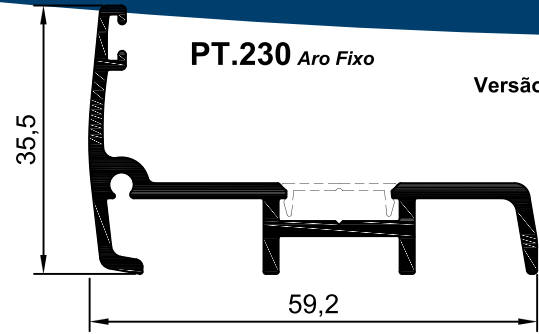

AT.30 Clip



PT.237 Aro Fixo

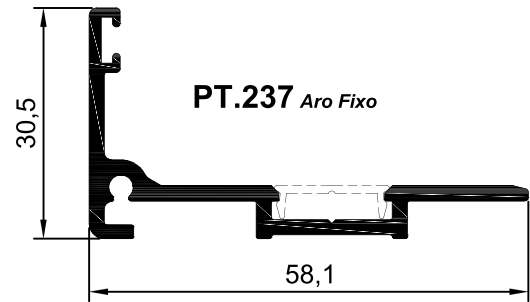

PT.251 Bite

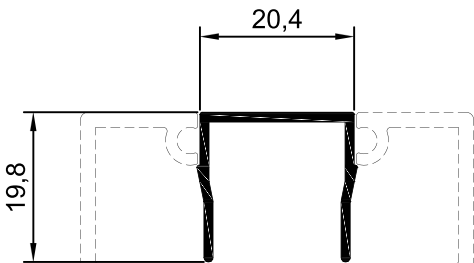

SP.24 Bite Redutor

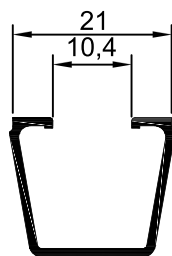

PT.238 Aro Fixo

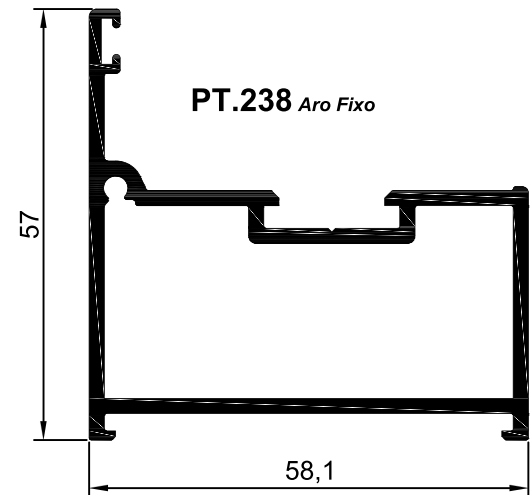

PT.252 Perfil Vedação

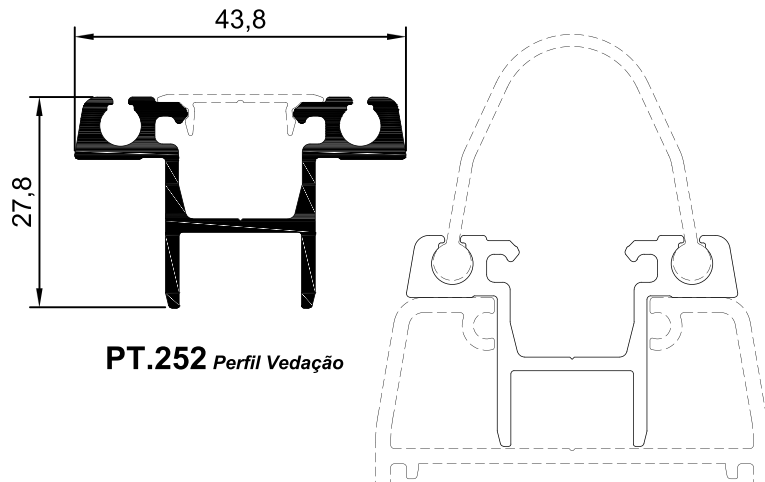

PT.214 Perfil Decorativo

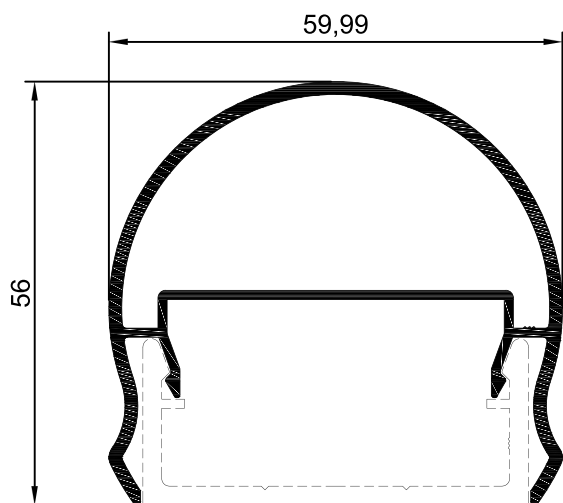

PT.213 Perfil Decorativo Capa

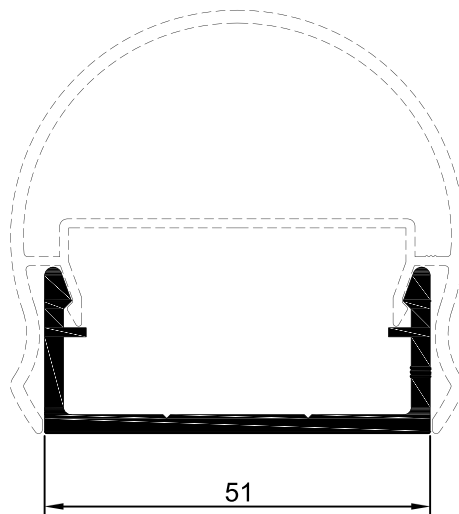

PT.229 Perfil Decorativo

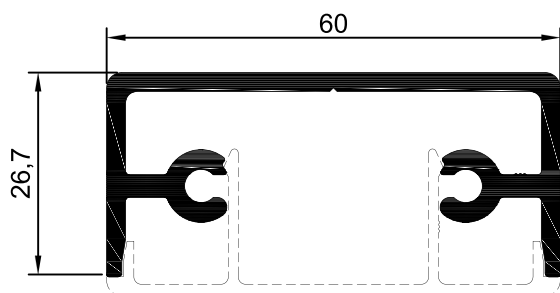

PT.218 Perfil Decorativo

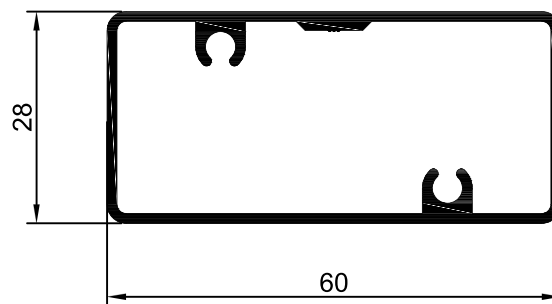

PT.208 Perfil Decorativo

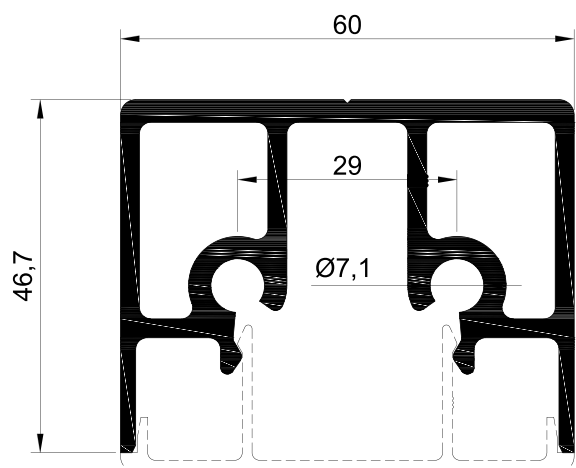

PT.209 Perfil Decorativo

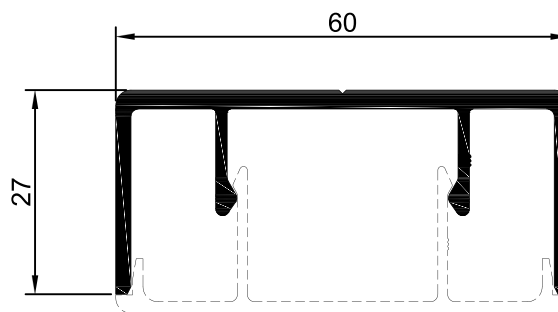

PT.210 Perfil Decorativo Capa

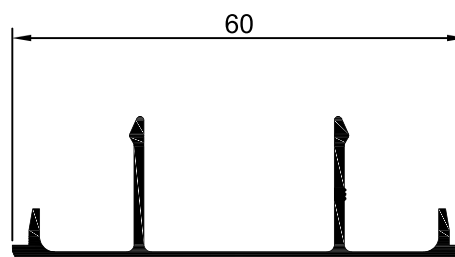

PT.225 *Capa Perfil Guia*

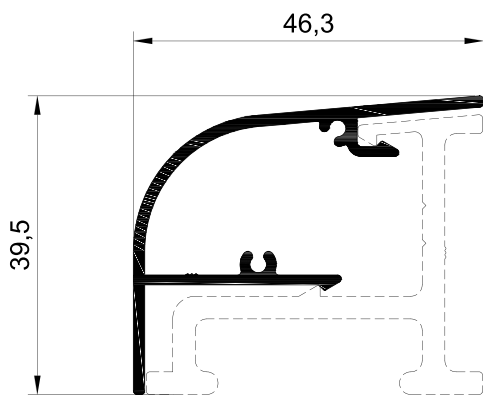

PT.224 *Perfil Guia*

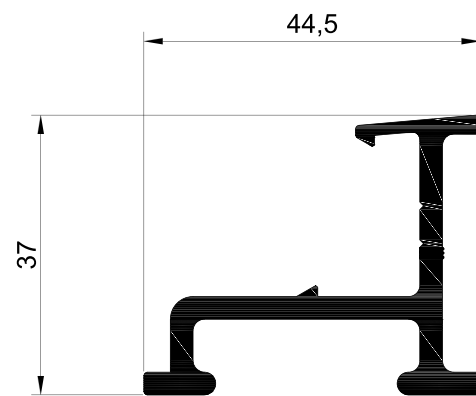

(Perfil fornecido em bruto ou acetinado)

PT.265 *Capa Perfil Guia*

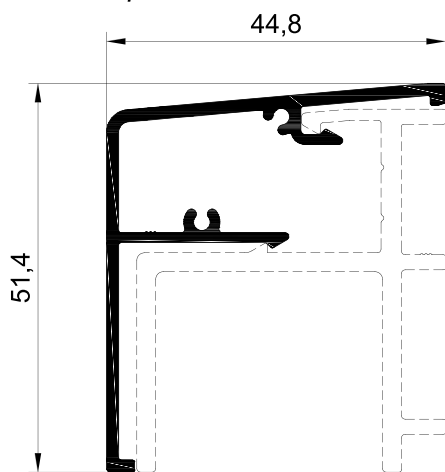

PT.264 *Perfil Guia*

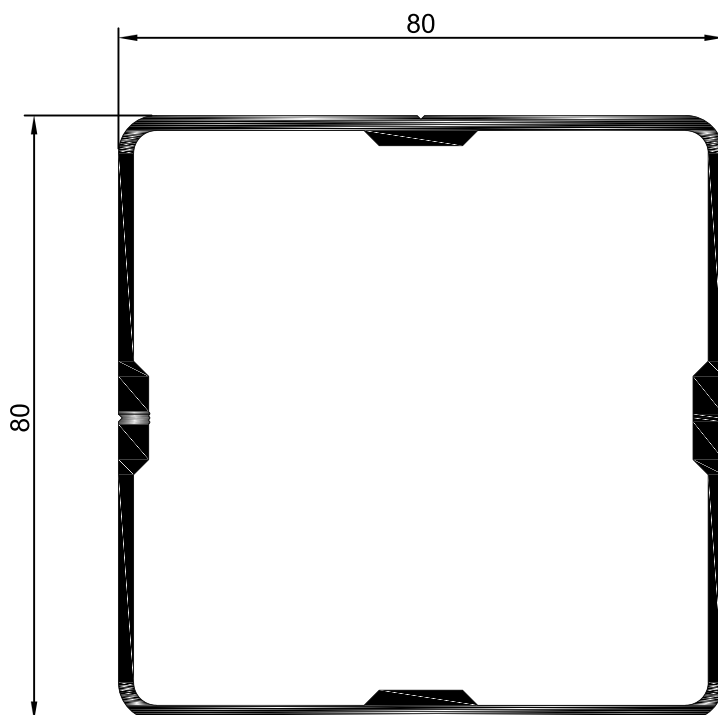
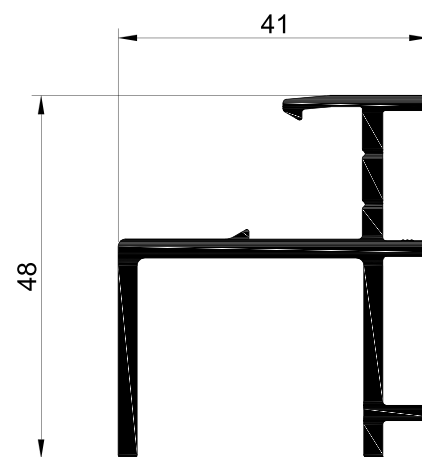

PT.203 *Perfil Poste*

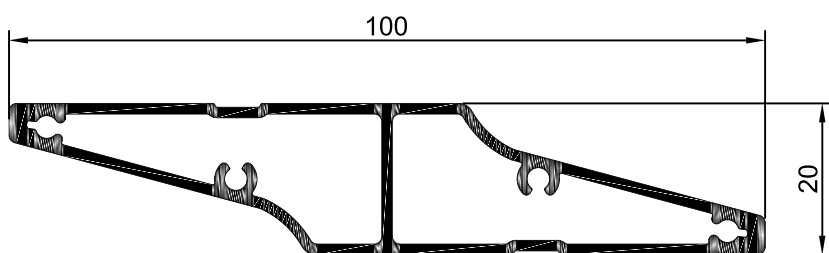
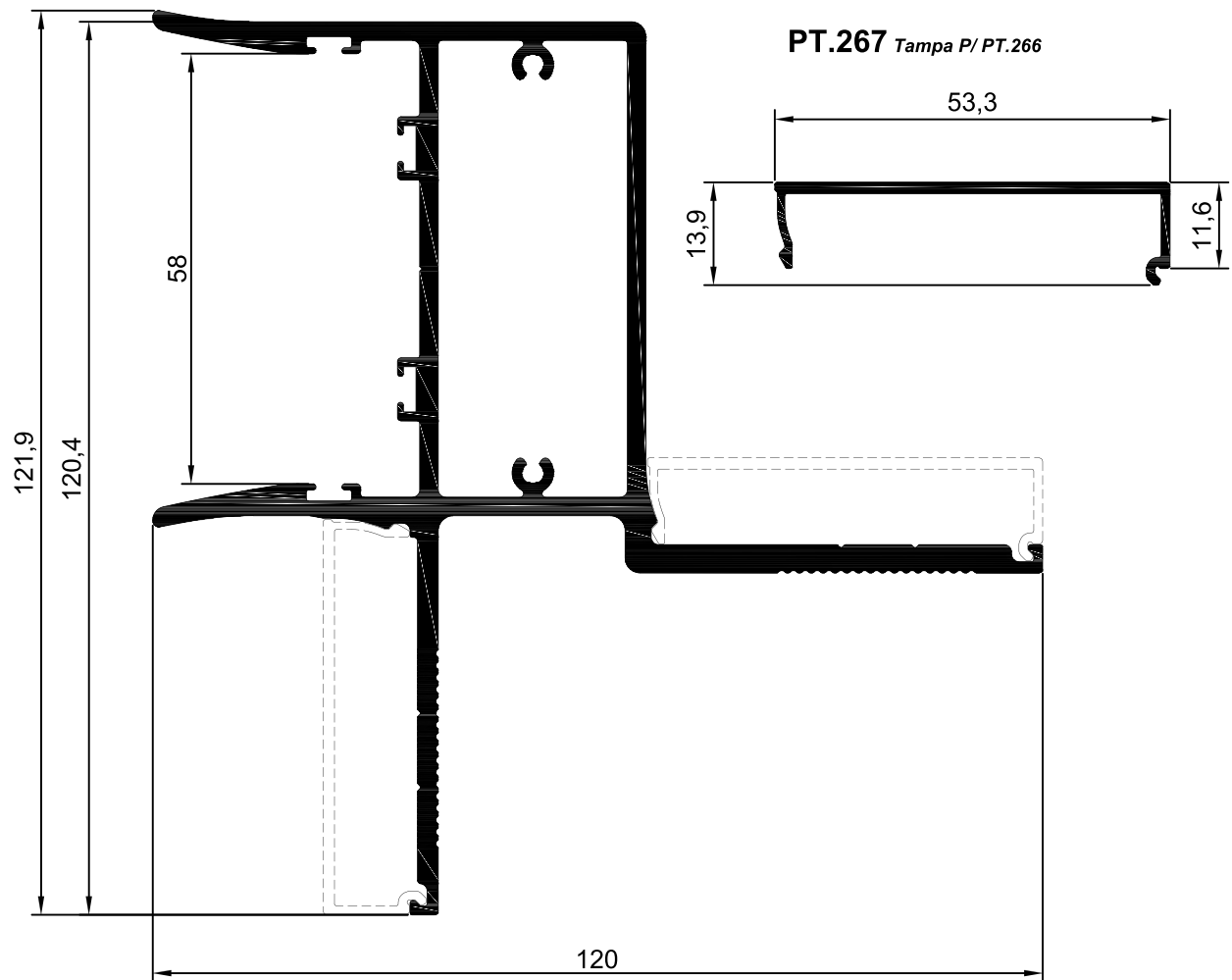

PT.250 Lâmina

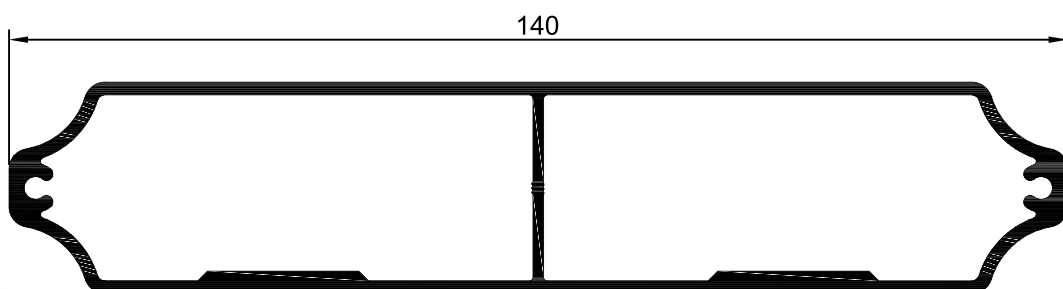

PT.217 Lâmina

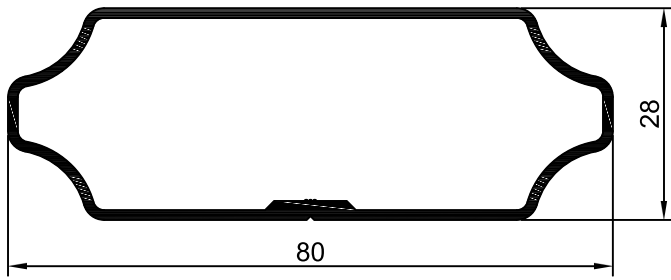

PT.202 *Lâmina*

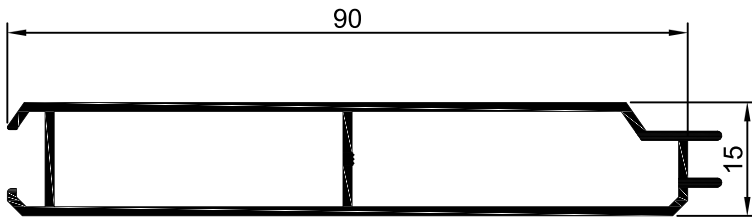

PT.216 *Lâmina*

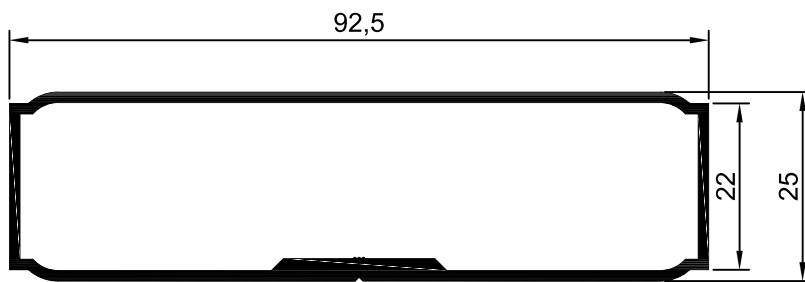

PT.205 *Lâmina*

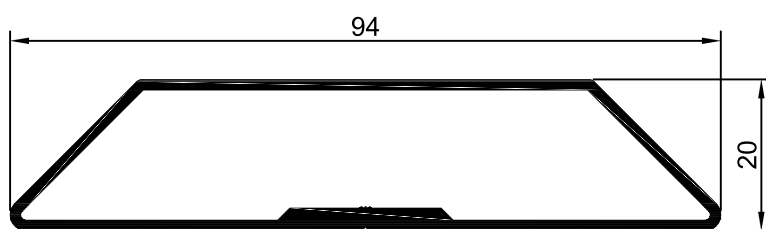

PT.206 *Lâmina*

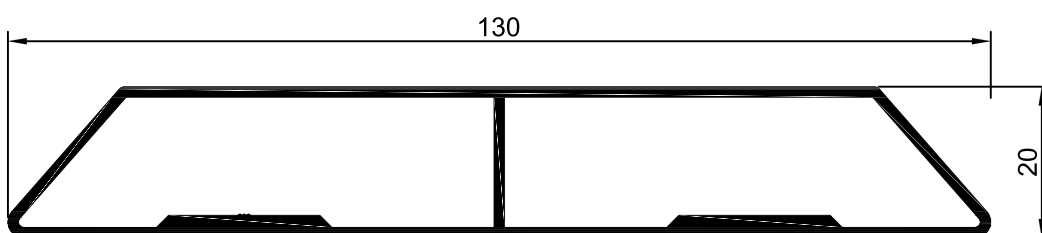

PT.212 *Lâmina*

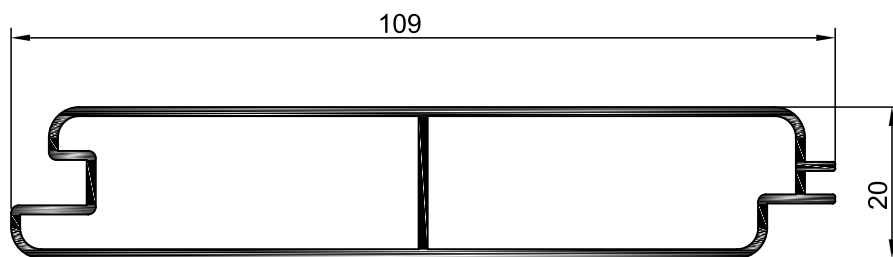

W.25 *Lâmina*

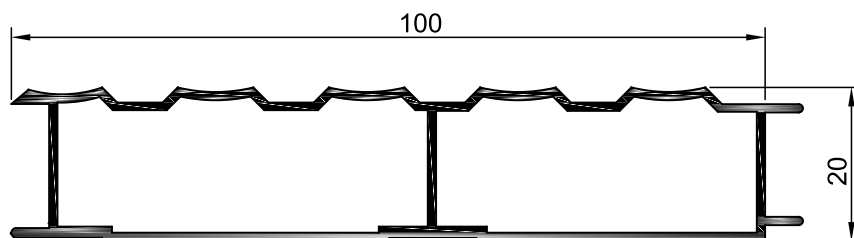

W.21 *Lâmina*

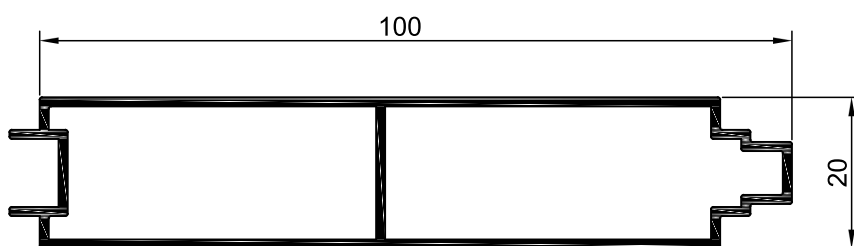

W.27 *Lâmina*

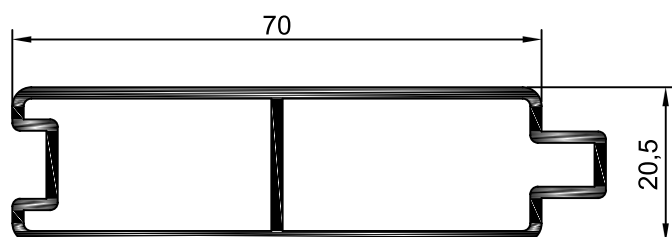

W.26 *Lâmina*

W.31 *Lâmina*

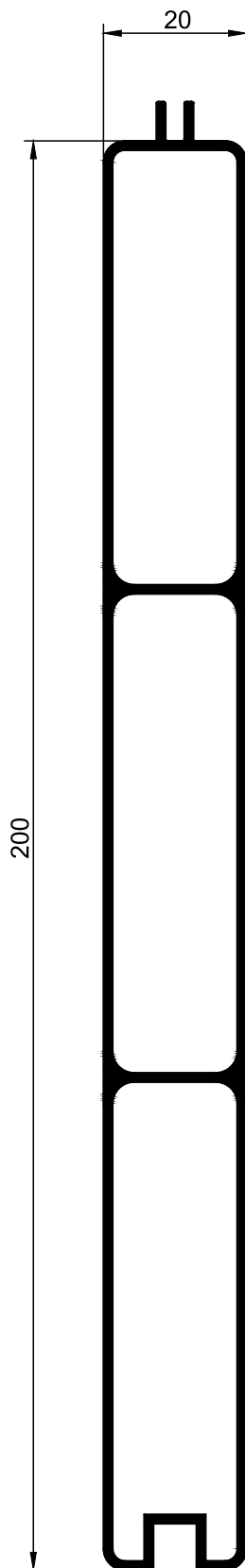

W.35 *Lâmina*

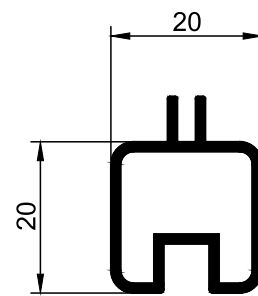

W.36 *Lâmina*

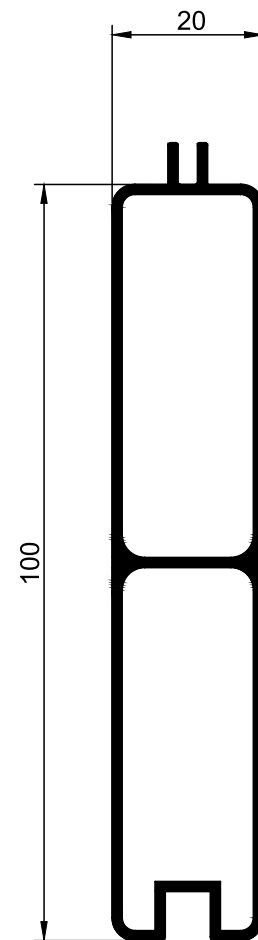

W.39 *Lâmina*

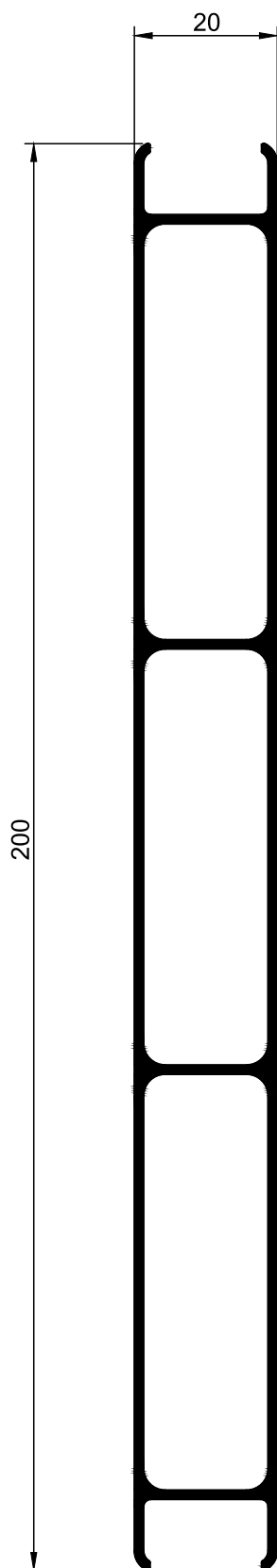

W.42 *Lâmina*

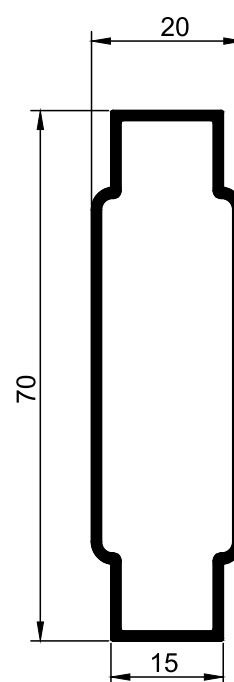

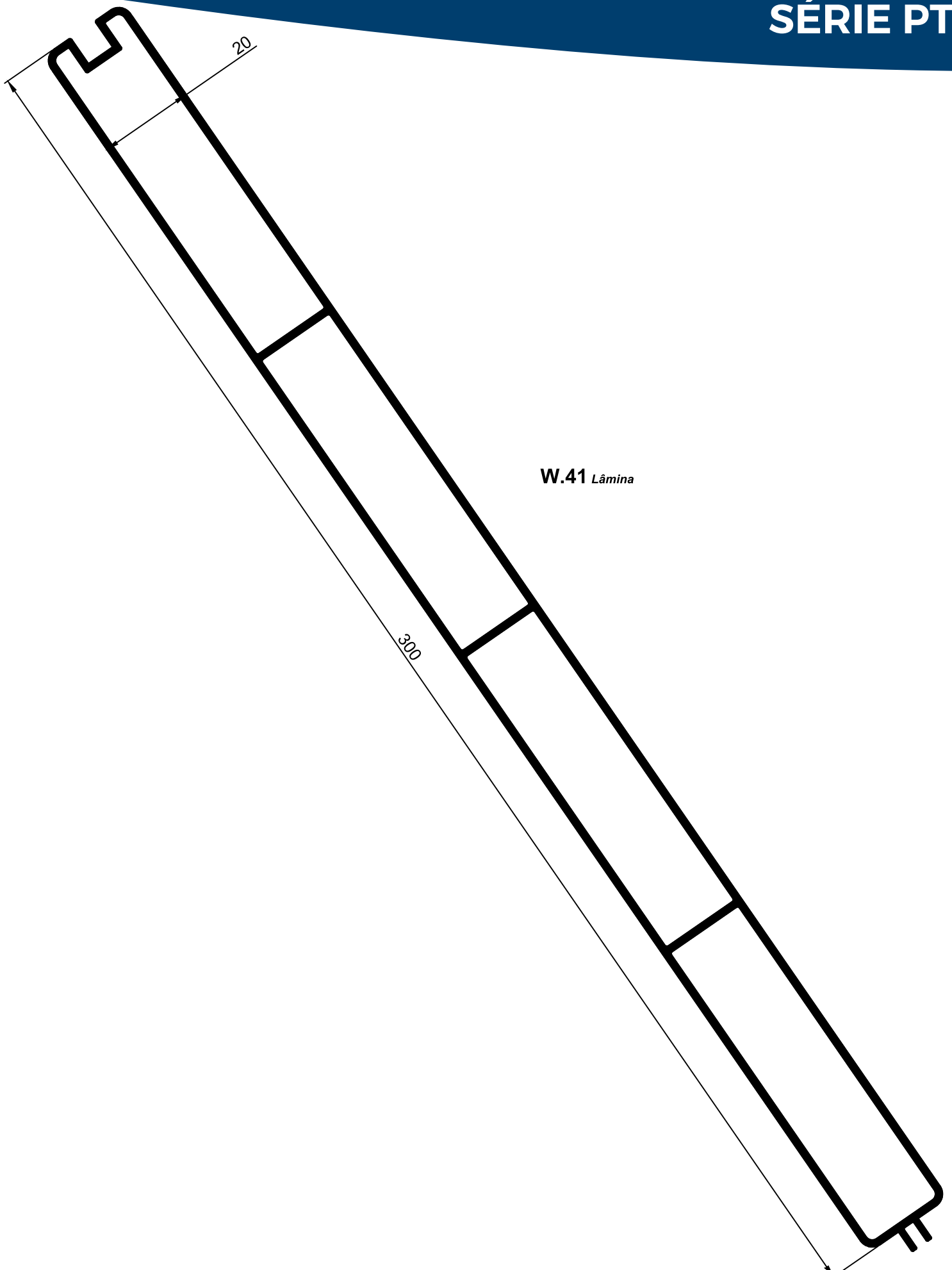

W.41 *Lâmina*

W.42 Lâmina

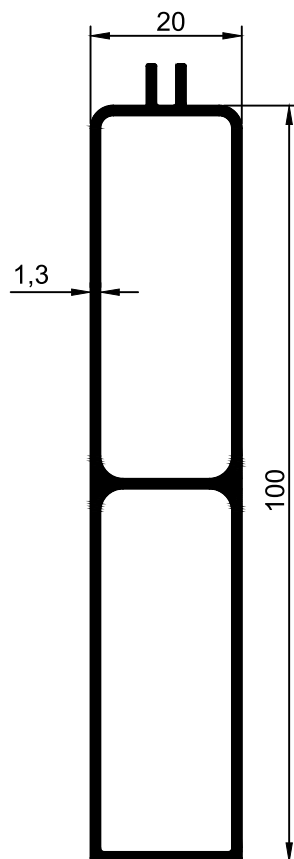
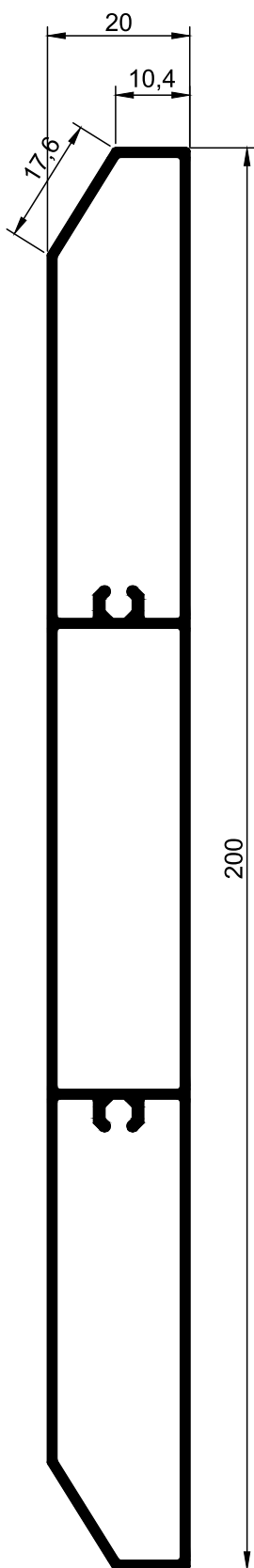

W.43 Lâmina

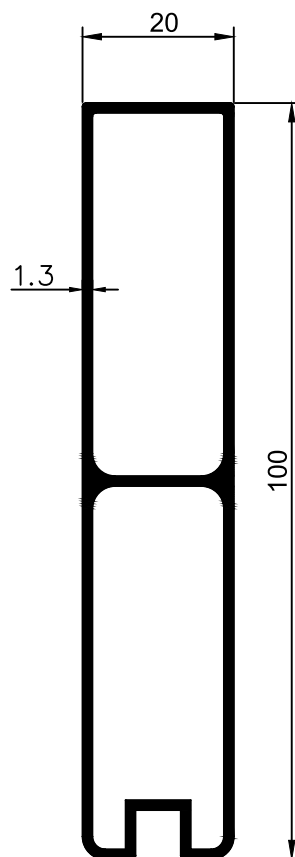

W.44 Lâmina

W.45 Lâmina

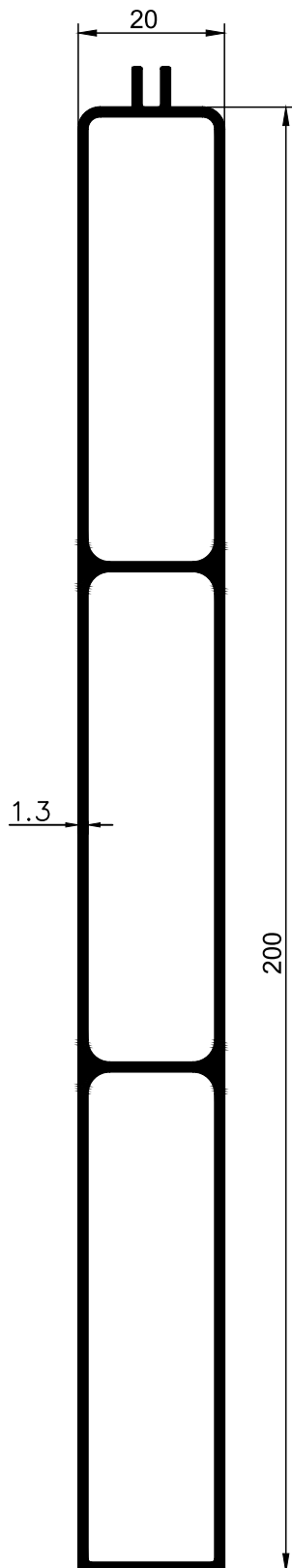

W.46 Lâmina

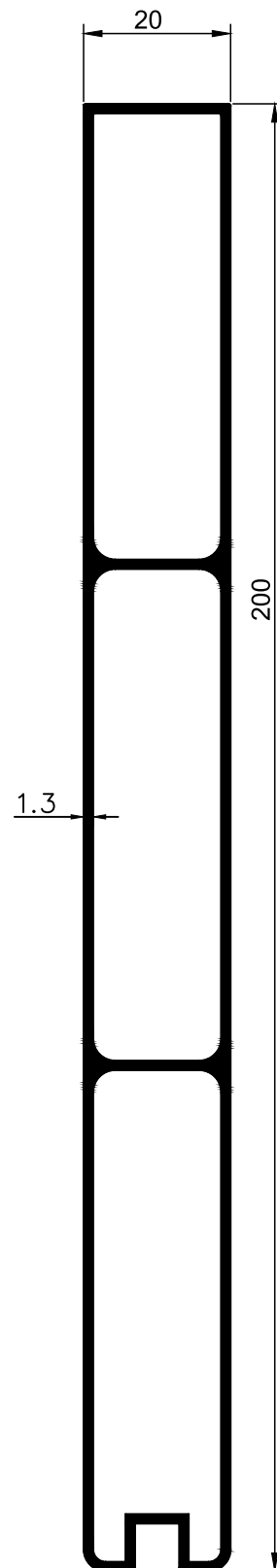

W.30 *Lâmina*

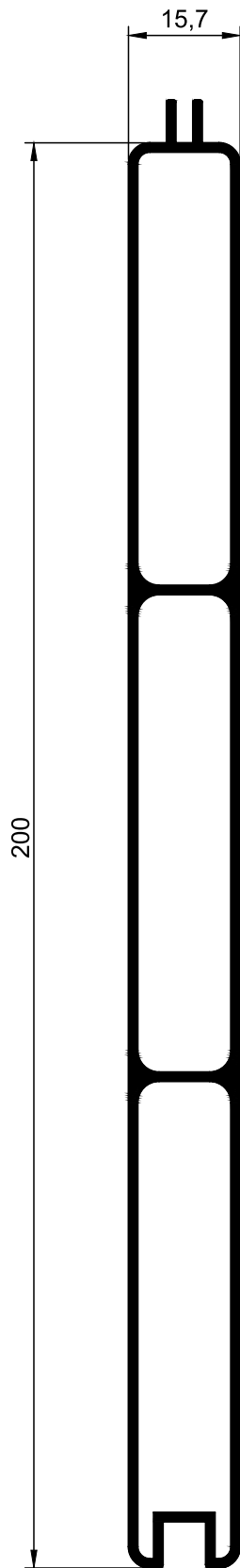

W.37 *Lâmina*

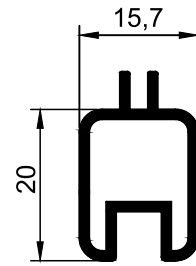

P.24 *Réguia*

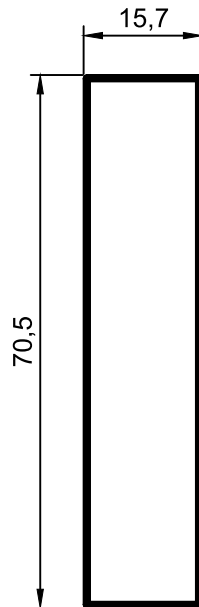



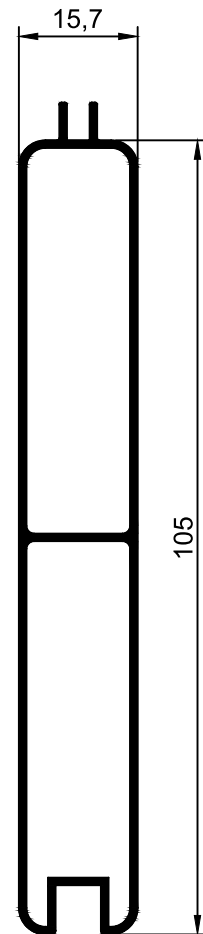

W.29 *Lâmina*









NORTALU[®]

ACESSÓRIOS

ARTIGO	DESCRIÇÃO	APLICAÇÃO
	L30053 Dobradiças P/ Portões (Soldar)	
	L30054 Dobradiças P/ Portões (Para Aparafusar)	
	L40632 Pivot-Fixador Dobradiças Portões	
	L40633 Pivot Dobradiças Portões	
	L40641 Batente Lateral Portões	
	L40642 Batente Chão Portões	

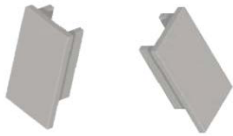
ARTIGO	DESCRIÇÃO	APLICAÇÃO
	L40643 Batente Chão 2ª Folha Portões	
	L40644 Batente Correr Portões	
	L40645 Batente Portões	
	L40651 Guia Correr Portões	
	L40654 Roldana Correr Portões	
	L40662 Tampa Para Portões C/ Furo	

Versão PT

ARTIGO	DESCRIÇÃO	APLICAÇÃO
	L40662 Tampa Para Portões S/ Furo	
	L40671 Tampa Para Pivot Latão	
	L40682 Tampa Para Poste 100mm	PT.15
	L40684 Tampa Para Poste 150mm	Q.21
	L40688 Tampa Aro Fixo Soldar	PT.02

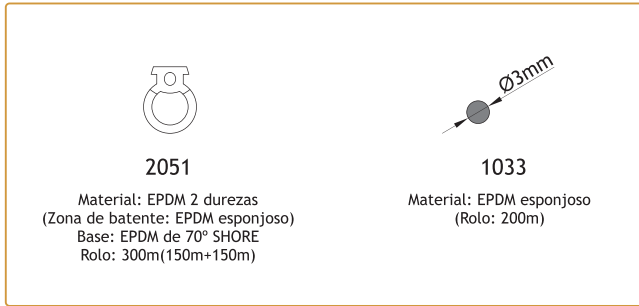

208008
208221

JUNTA DE ESTANQUIDADE 2051
JUNTA VD 1033

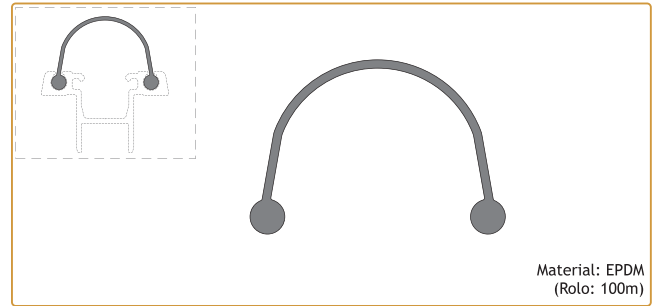

208222

VEDANTE 2120

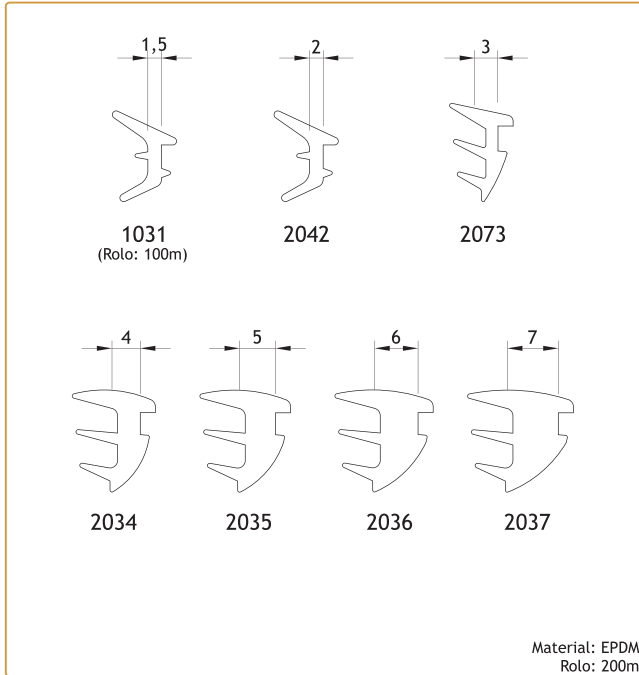

208223 JUNTA DE CUNHA 1031
208191 JUNTA DE CUNHA 2042
208195 JUNTA DE CUNHA 2034
208196 JUNTA DE CUNHA 2035

208215 JUNTA DE CUNHA 2036
208904 JUNTA DE CUNHA 2037
208199 JUNTA DE CUNHA 2073

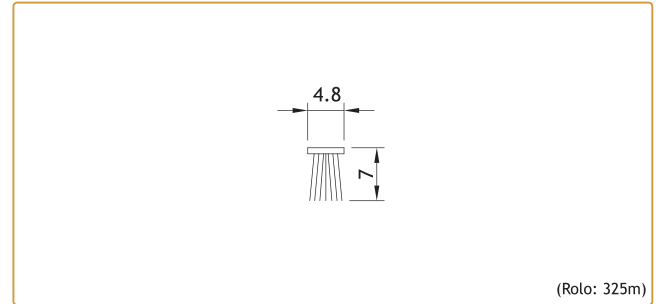

208564

VEDANTE PELÚCIA 4.8x7 Cinza

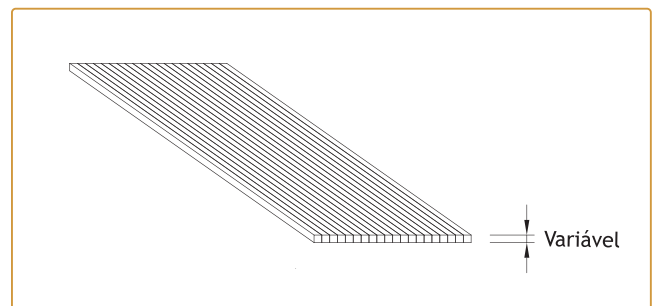

218132 CALÇO P/VIDRO 99x33x1
218113 CALÇO P/VIDRO 79x40x2
218109 CALÇO P/VIDRO 79x40x3

218111 CALÇO P/VIDRO 79x40x4
218112 CALÇO P/VIDRO 79x49x5

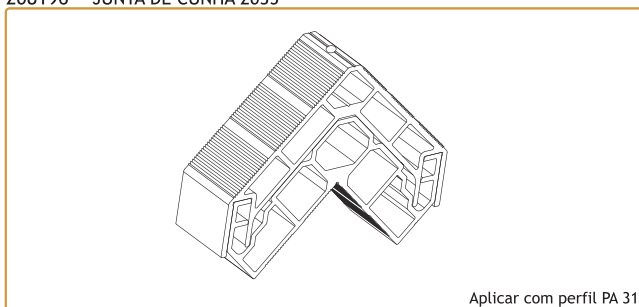

204162

ESQUADRO ESPECIAL PA

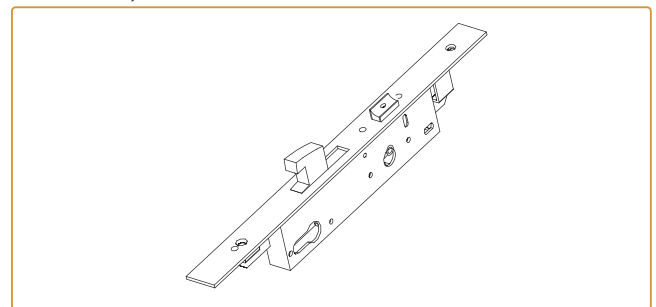

201050

FECHADURA PRUMO 7716x35

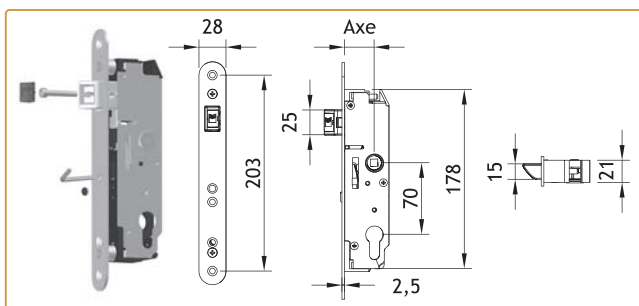

201134

FECHADURA PRUMO PA T40

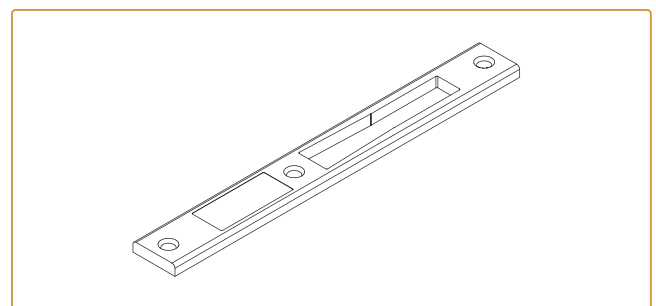

280220

TESTA FECHADURA PRUMO 2000

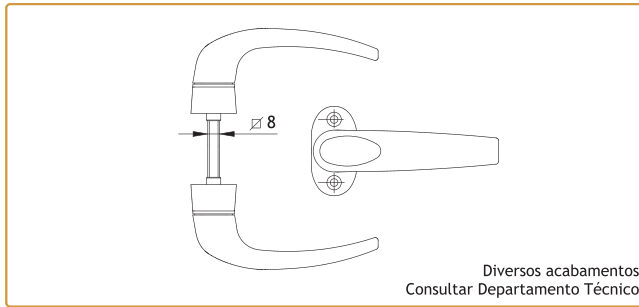

200028

Diversos acabamentos
Consultar Departamento Técnico

PUXADOR DUPLO 874.31

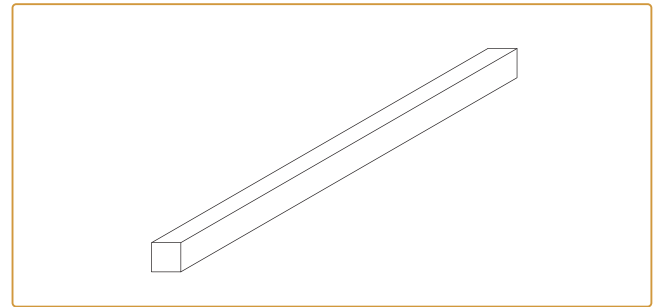

227301

QUADRA AÇO 8mm PARA PUXADOR 874

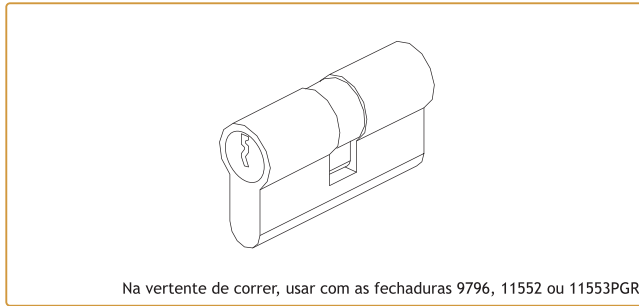

Na vertente de correr, usar com as fechaduras 9796, 11552 ou 11553PGR

230017

SEGREDO 30/30 COM 3 CHAVES



202611

DOBRADIÇA 2 ABAS 1146.1/62.5

2 Dobradiças = 160Kg
3 Dobradiças = 180Kg

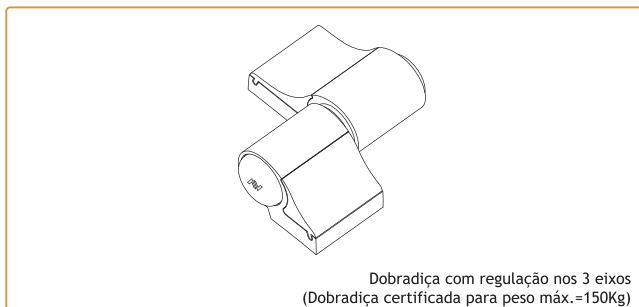

Dobradiça com regulação nos 3 eixos
(Dobradiça certificada para peso máx.=150Kg)

202010
202012
202020

DOBRADIÇA MECÂNICA 2 ABAS 1145/60
DOBRADIÇA MECÂNICA 2 ABAS 1145/79
DOBRADIÇA MECÂNICA 2 ABAS 1145/93SM

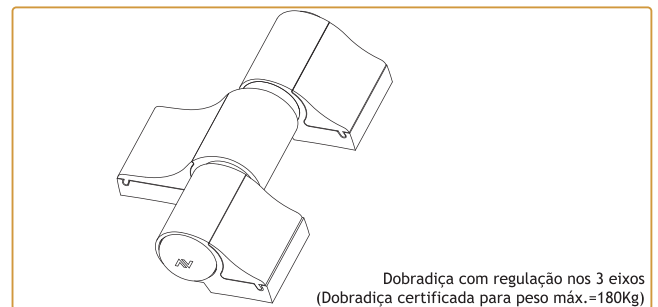

202610

DOBRADIÇA MECÂNICA 3 ABAS 1145.3/60

Dobradiça com regulação nos 3 eixos
(Dobradiça certificada para peso máx.=180Kg)

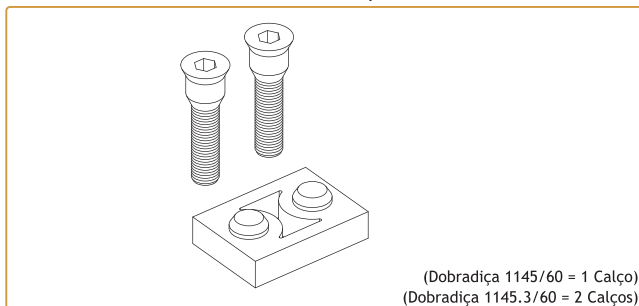

(Dobradiça 1145/60 = 1 Calço)
(Dobradiça 1145.3/60 = 2 Calços)

218170

CALÇO PARA DOBRADIÇA MECÂNICA 1145.703/7

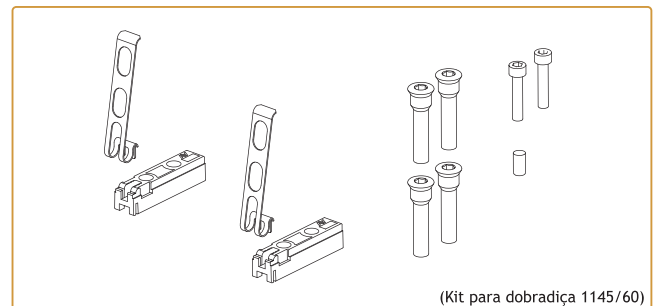

223100

KIT DE FIXAÇÃO PARA MECÂNICA 1145.705

(Kit para dobradiça 1145/60)

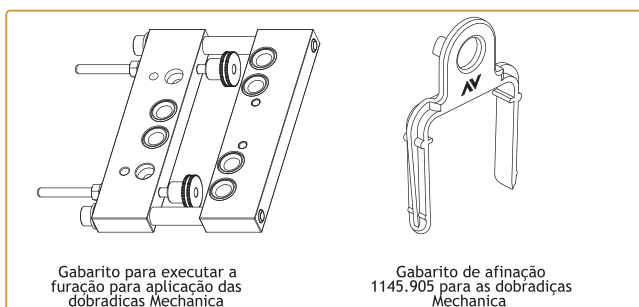

Gabarito para executar a
furação para aplicação das
dobradiças Mecânica

Gabarito de afinação
1145.905 para as dobradiças
Mecânica

211101

GABARITO PARA FURAÇÃO 1145.908

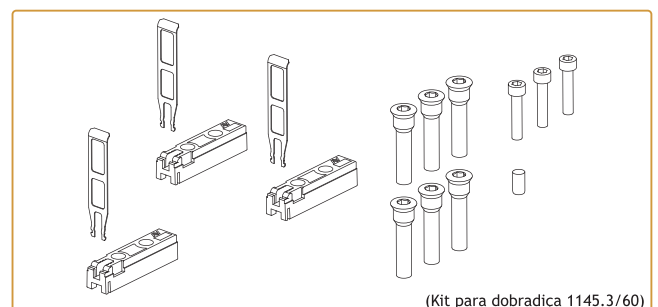

223020

KIT DE FIXAÇÃO PARA MECÂNICA 1145.715

(Kit para dobradiça 1145.3/60)



202352

DOBRADIÇA PA INOX 100Kg

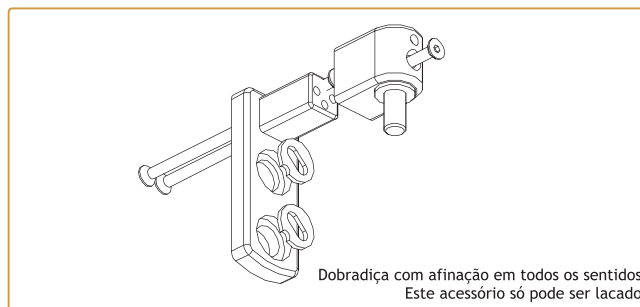

202164

DOBRADIÇA C/REGULAÇÃO PA 24000

Dobradiça com afinação em todos os sentidos
Este acessório só pode ser lacado

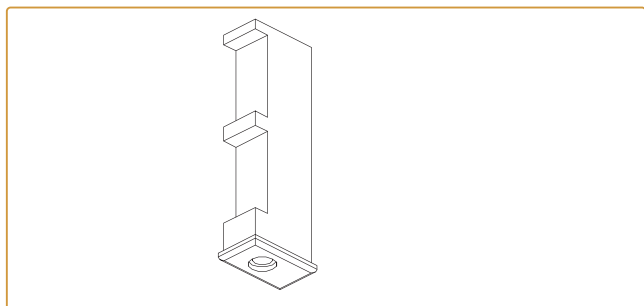

215143

PEÇA PARA DOBRADIÇA PA 17131 (Br./Pr.)

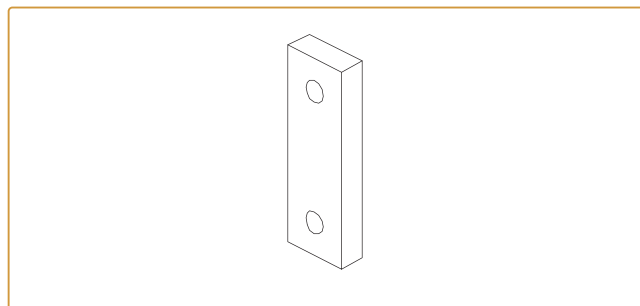

215175

PLACA DE REFORÇO P/DOB. 24000



227124

PIVOT SUPERIOR INOX

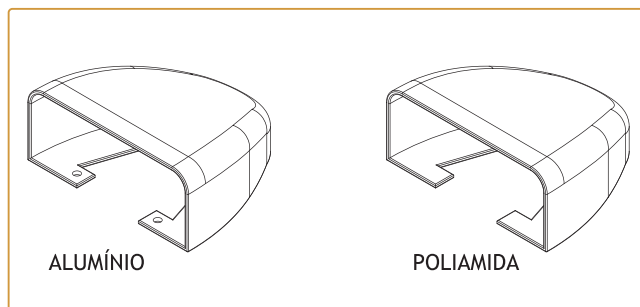

207332
207333

TAMPA EM ALUMÍNIO PARA PIVOT SUPERIOR INOX
TAMPA EM POLIAMIDA PARA PIVOT SUPERIOR INOX

ALUMÍNIO

POLIAMIDA



227127

PIVOT SUPERIOR Nº.2 INOX C/CAPA EM POLIAMIDA

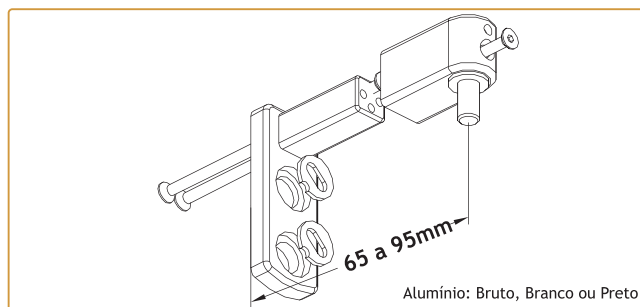

227123

PIVOT SUPERIOR Nº.3 65/95mm ALUMÍNIO

Alumínio: Bruto, Branco ou Preto



210180

ANEL PIVOT Nº.2 INOX (LATÃO)



210181

ANEL PIVOT Nº.3 INOX (POLIAMIDA)

Versão PT Plus

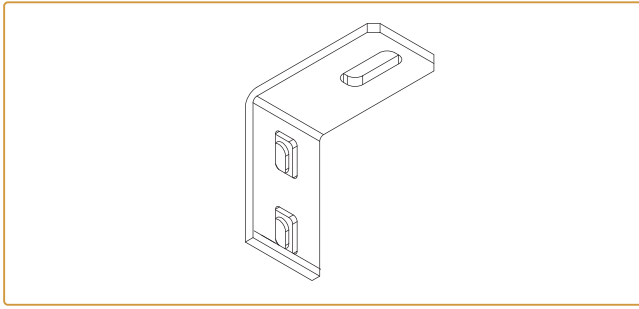

227119
227120

PIVOT SUP./INF. Nº. 1 INOX
PIVOT SUP./INF. Nº. 1 GALVANIZADO

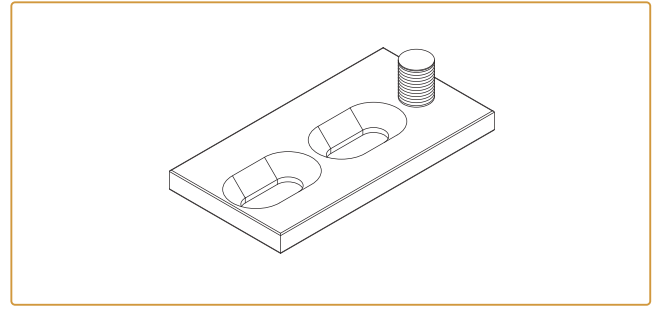

227121
227122

PIVOT INFERIOR Nº. 1 INOX
PIVOT INFERIOR Nº. 1 GALVANIZADO



227125

PIVOT INFERIOR Nº. 2 INOX



227126

PIVOT INFERIOR Nº. 3 INOX

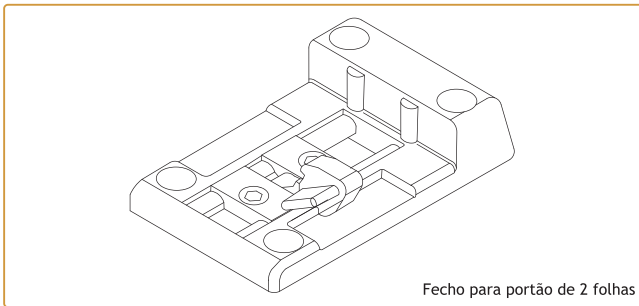

201570

FECHO INFERIOR PVC PARA 2 FOLHAS PA 16201Pr.

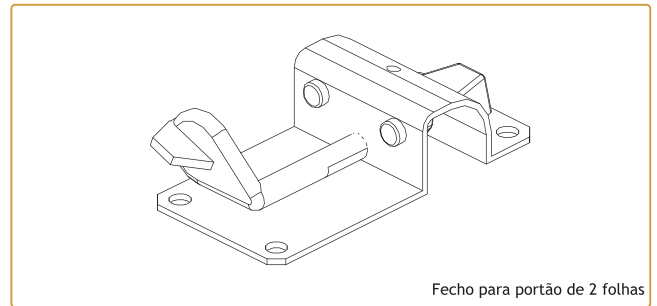

201025

FECHO INFERIOR inox PARA 2 FOLHAS PA 16011

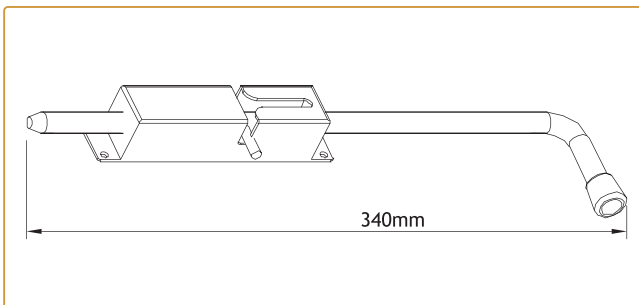

201424

FECHO CULATRA 16064 INOX



212915

CONJUNTO UNIÃO P/MONTANTE RA 857

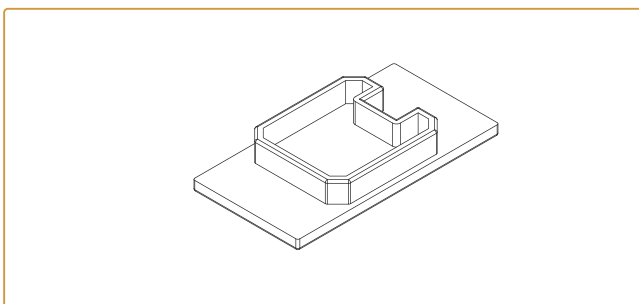

210039

TOPO SIMPLES PARA PA 31

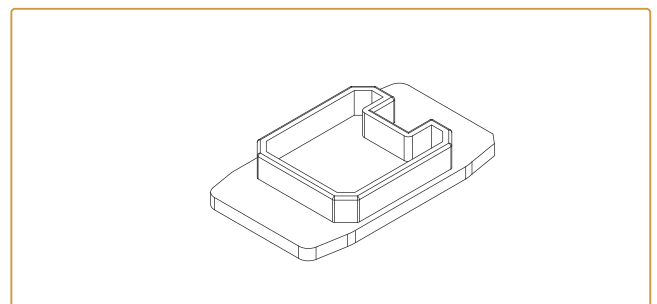

210040

TOPO SIMPLES PARA PA 41

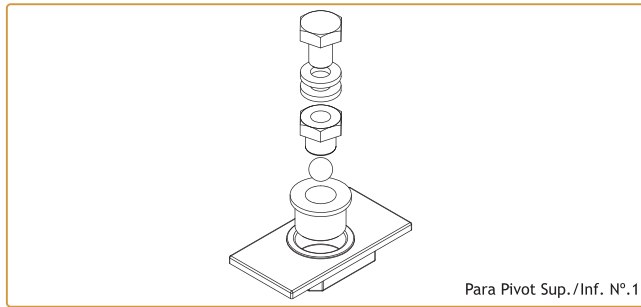

Para Pivot Sup./Inf. Nº.1

210042

TOPO PIVOT SUPERIOR Nº.2 PARA PA 31

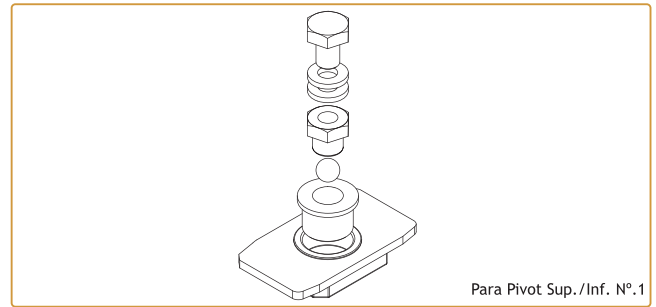

Para Pivot Sup./Inf. Nº.1

210045

TOPO PIVOT SUPERIOR Nº.5 PARA PA 41

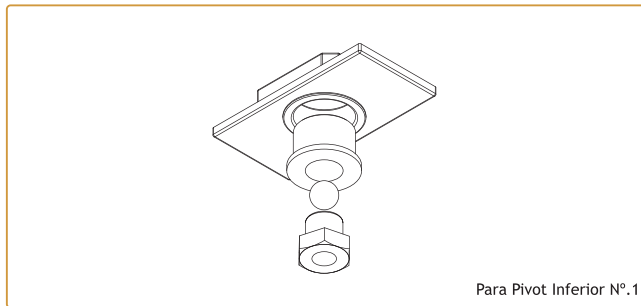

Para Pivot Inferior Nº.1

210041

TOPO PIVOT INFERIOR Nº.1 PARA PA 31

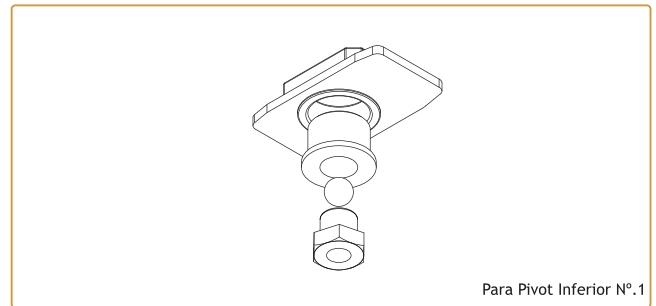

Para Pivot Inferior Nº.1

210044

TOPO PIVOT INFERIOR Nº.4 PARA PA 41

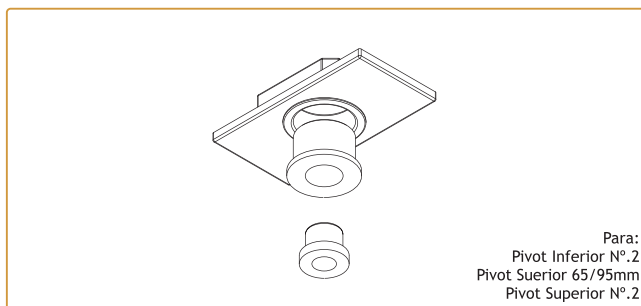

Para:
Pivot Inferior Nº.2
Pivot Superior 65/95mm
Pivot Superior Nº.2

210043

TOPO PIVOT Nº.3 PARA PA 31

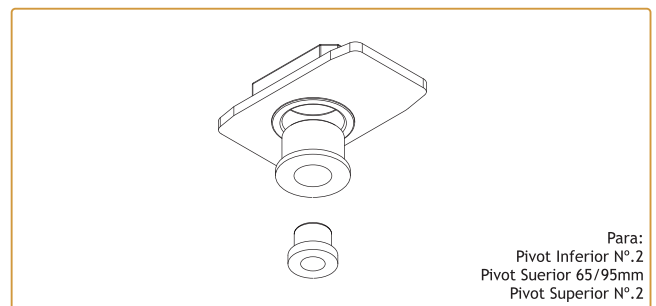

Para:
Pivot Inferior Nº.2
Pivot Superior 65/95mm
Pivot Superior Nº.2

210046

TOPO PIVOT Nº.6 PARA PA 41

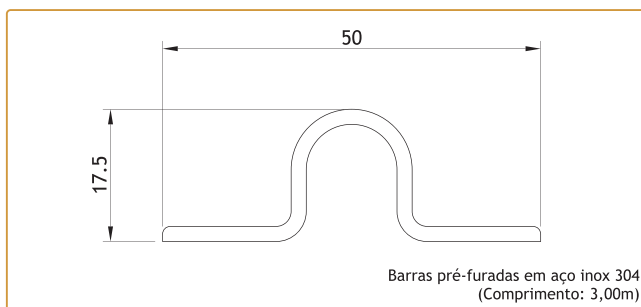

Barras pré-furadas em aço inox 304
(Comprimento: 3,00m)

207136

GUIA INOX PA 20049 (3m)

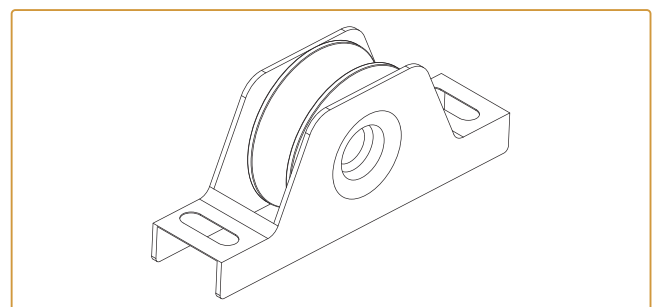

207280
207281

ROLAMENTO PA Nº.3 INOX
ROLAMENTO PA Nº.4 AÇO GALVANIZADO

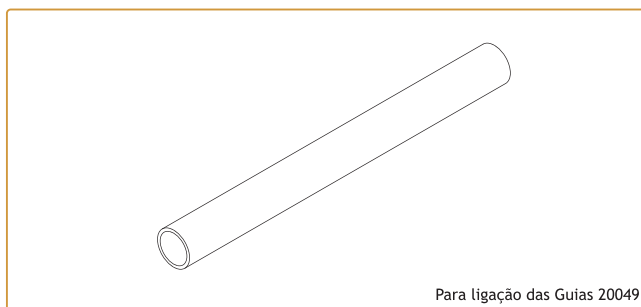

Para ligação das Guias 20049

232009

UNIÃO PARA GUIA INOX 20052

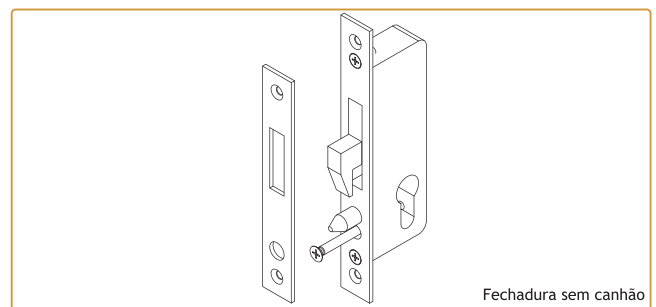

Fechadura sem canhão

201038

FECHADURA DE GANCHO SEM CILINDRO 9796

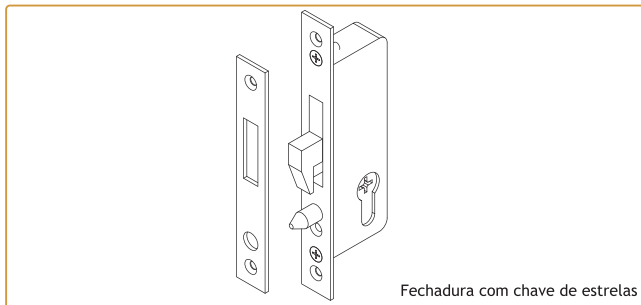

Fechadura com chave de estrelas

201039

FECHADURA DE GANCHO 9796/S

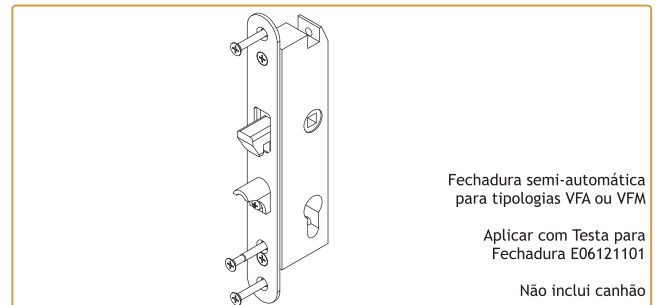

Fechadura semi-automática para tipologias VFA ou VFM

Aplicar com Testa para Fechadura E06121101

Não inclui canhão

201614

FECHADURA PRUMO 11552

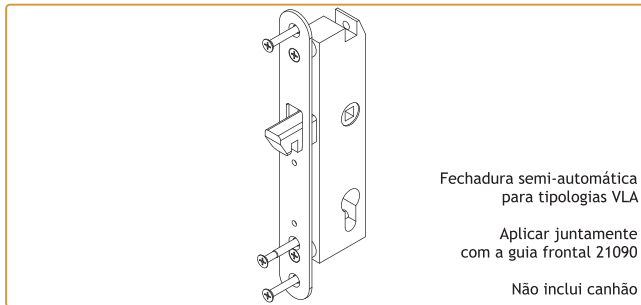

Fechadura semi-automática para tipologias VLA

Aplicar juntamente com a guia frontal 21090

Não inclui canhão

201613

FECHADURA PRUMO 11553 PGR

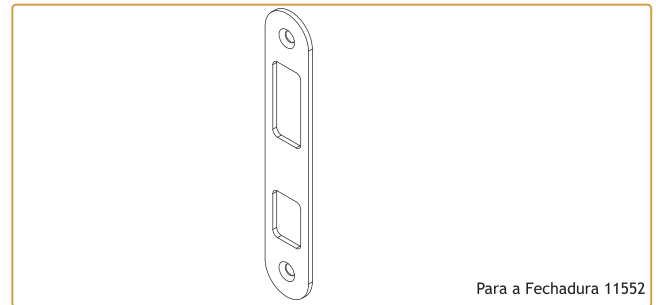

Para a Fechadura 11552

280243

TESTA PARA FECHADURA E06121101

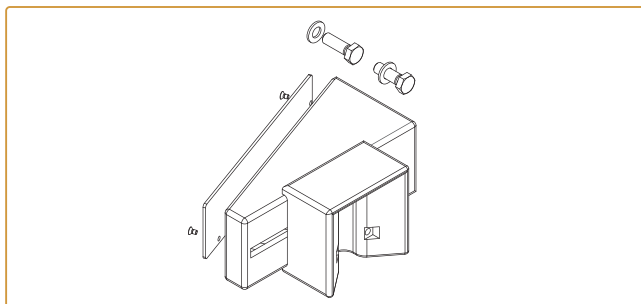

FECHO LATERAL REG. 21060

201813

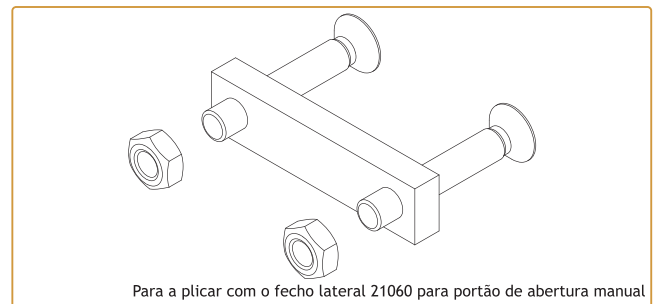

Para a plicar com o fecho lateral 21060 para portão de abertura manual

202100

CONTRA-FECHO INOX 21080

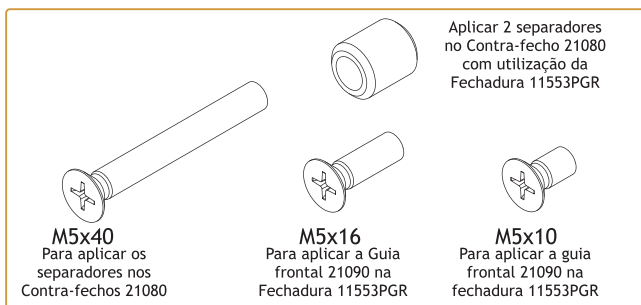

Aplicar 2 separadores no Contra-fecho 21080 com utilização da Fechadura 11553PGR

M5x40

Para aplicar os separadores nos Contra-fechos 21080

M5x16

Para aplicar a Guia frontal 21090 na Fechadura 11553PGR

M5x10

Para aplicar a guia frontal 21090 na fechadura 11553PGR

210012

SEPARADOR 714

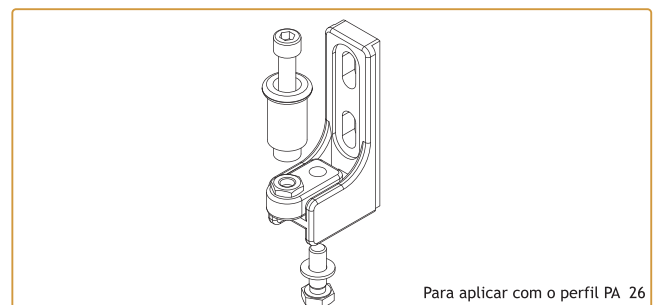

Para aplicar com o perfil PA 26

207508

GUIA REGULÁVEL 21010

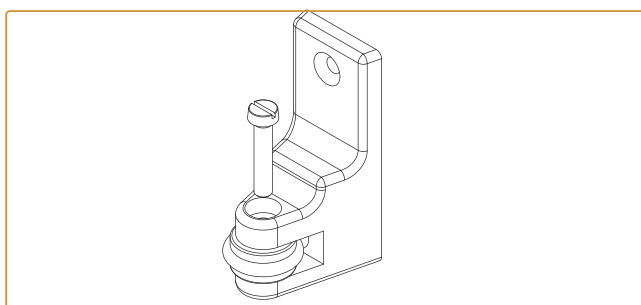

GUIA FRONTAL 21090

207138

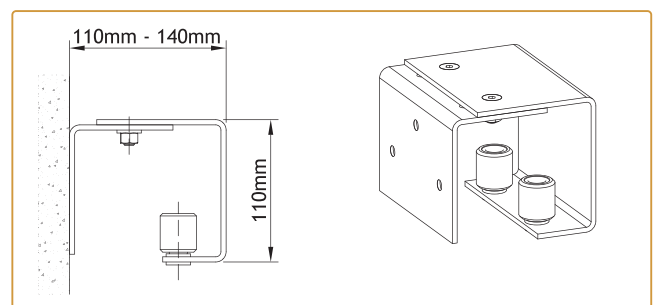

223053
223054

KIT GUIAS DE CORRER INOX
KIT GUIAS DE CORRER ALUMÍNIO



Alternativa à União 2120, para fixação inferior do perfil PA 26

232012

UNIÃO PA 18153

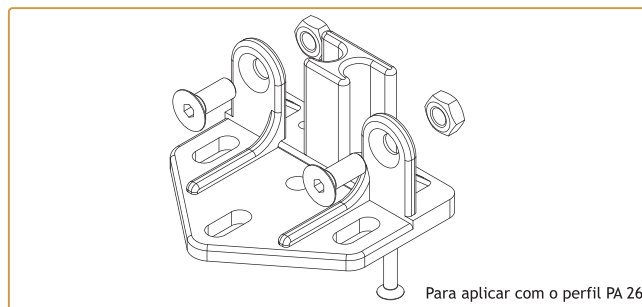

Para aplicar com o perfil PA 26

232011

UNIÃO 21020

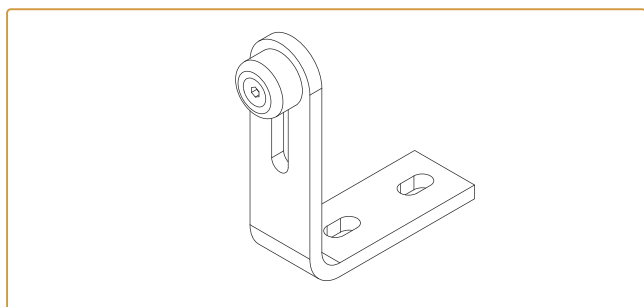

214029
214028

BATENTE PA Nº.1 INOX
BATENTE PA Nº.2 GALVANIZADO

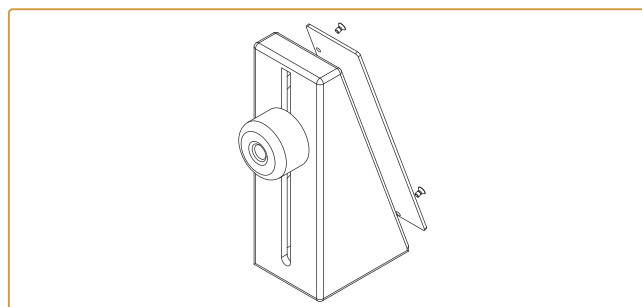

214021

BATENTE CORRER 21110

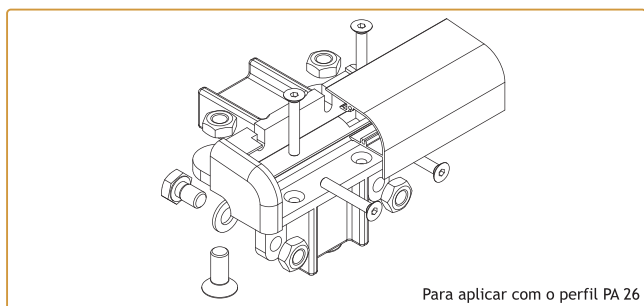

Para aplicar com o perfil PA 26

213012

CANTO 21030

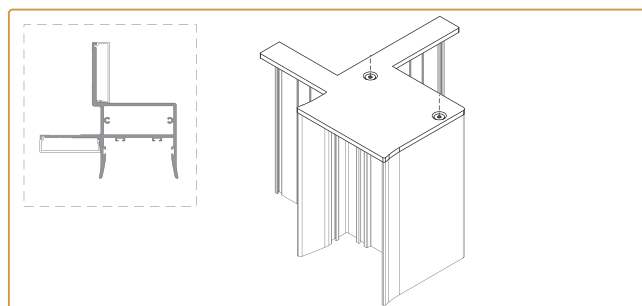

210038

TOPO PARA PA 66

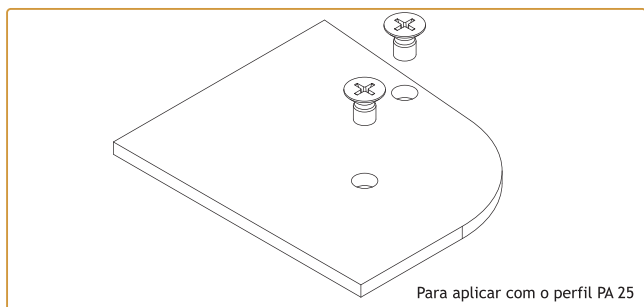

Para aplicar com o perfil PA 25

210033

TOPO GUIA 21042

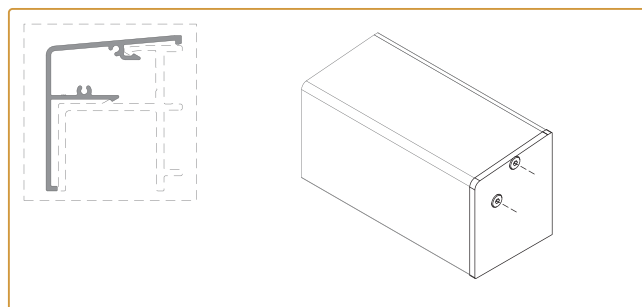

210037

TOPO PARA PA 65

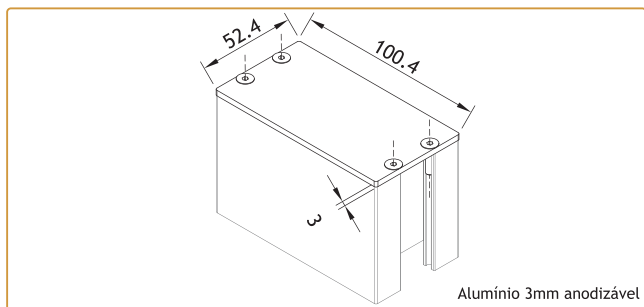

Alumínio 3mm anodizável

210008

TOPO PARA PA 31

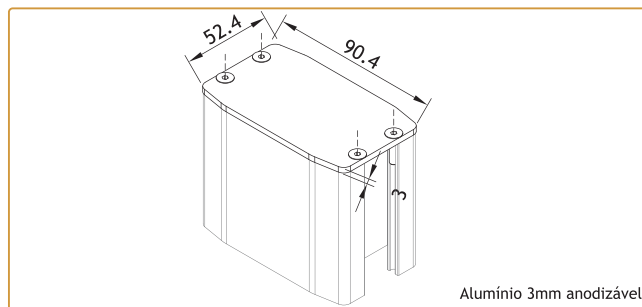

Alumínio 3mm anodizável

210036

TOPO PARA PA 41

Versão PT Plus

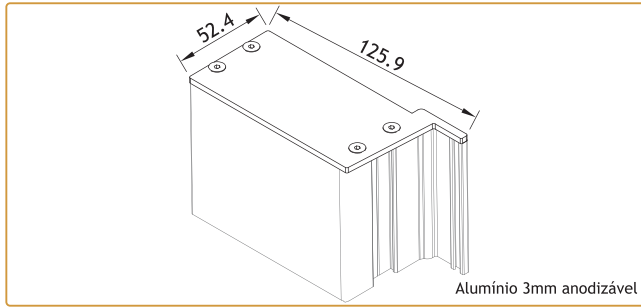

210034

TOPO PARA PA 37

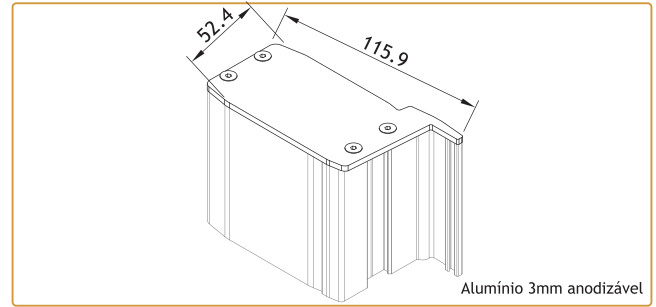

210007

TOPO PARA PA 30

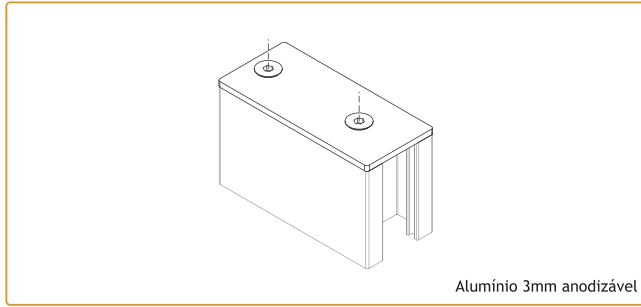

210009

TOPO PARA PA 34

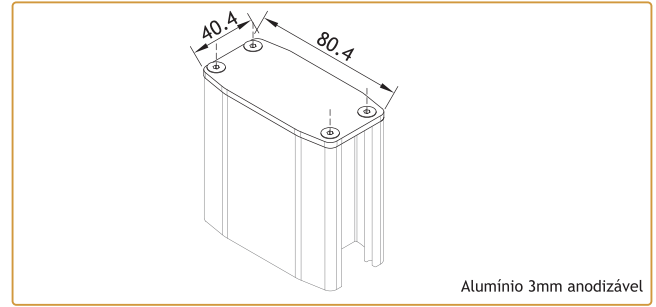

210052

TOPO PARA PA 42

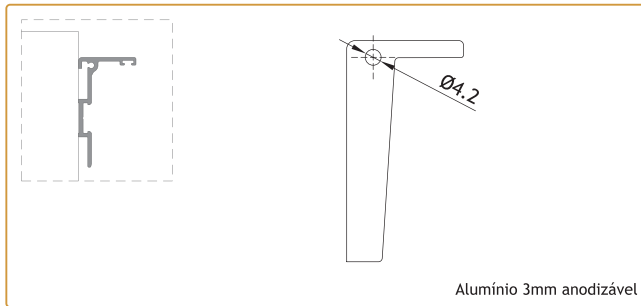

210049

TOPO PA 37B

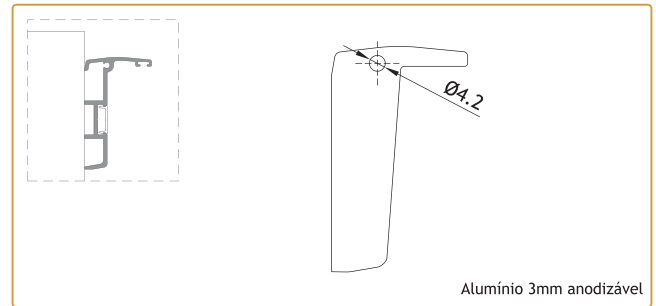

210048

TOPO PA 30B

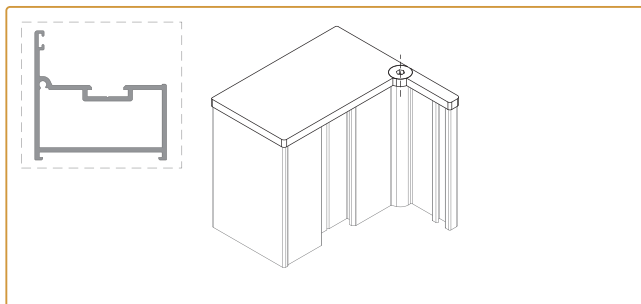

210035

TOPO PARA PA 38

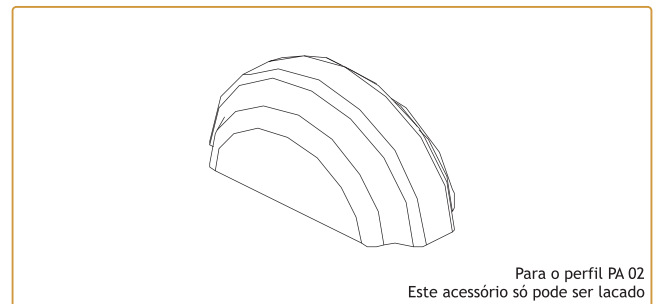

210284

Para o perfil PA 02
Este acessório só pode ser lacado

TOPO GER-001

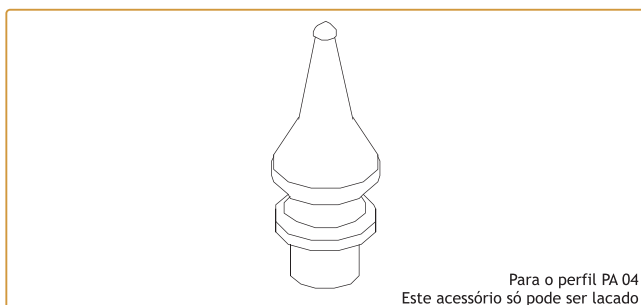

210021

Para o perfil PA 04
Este acessório só pode ser lacado

TOPO DECORATIVO GER-002

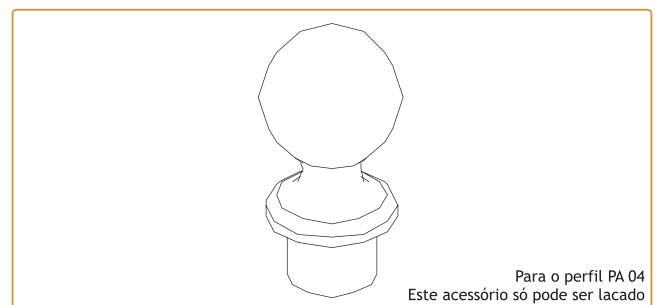

210022

Para o perfil PA 04
Este acessório só pode ser lacado

TOPO DECORATIVO GER-003

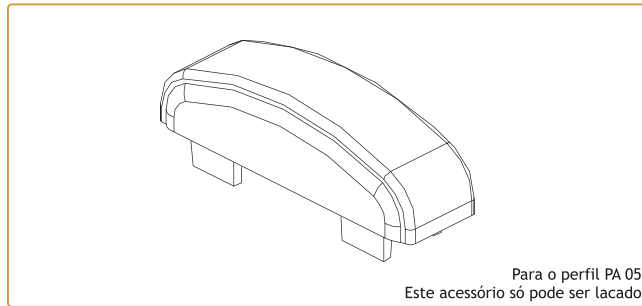

210003

TOPO PARA PA 05

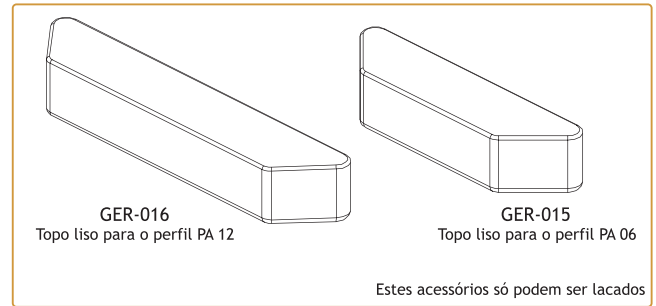

210249
210253

TOPO PA 06 GER-015
TOPO PA 12 GER-016

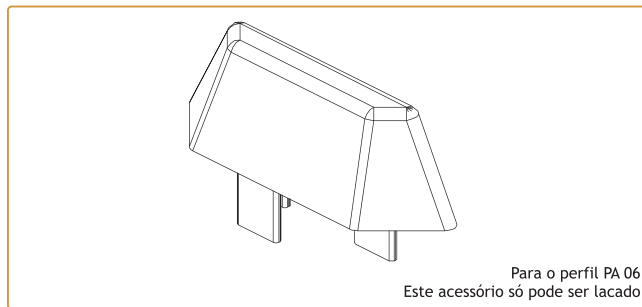

210004

TOPO PARA O PA 06

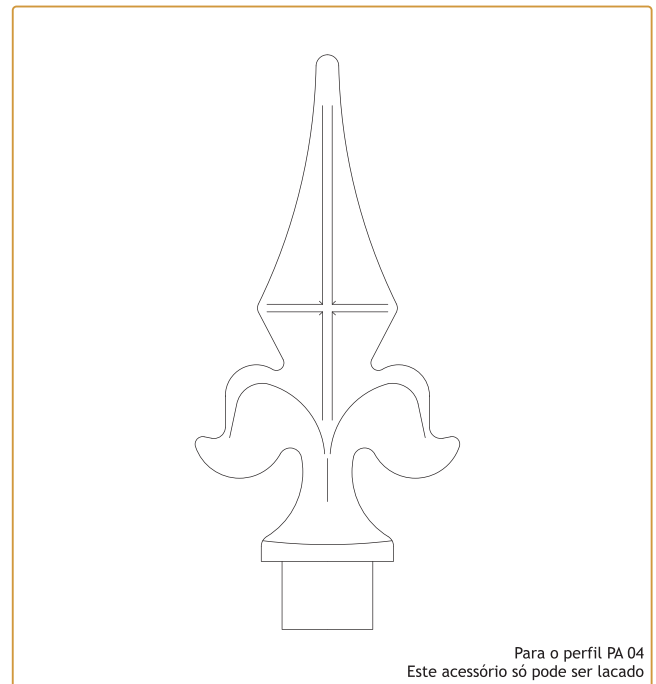

210023

TOPO DECORATIVO GER-006

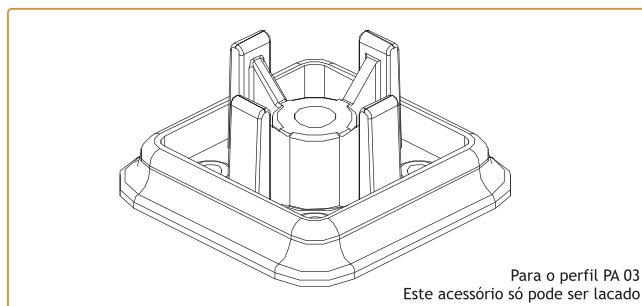

206150

PATER VERTICAL GER-004

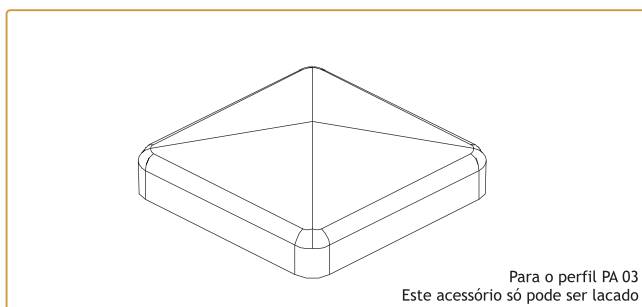

207005

TAMPA GER-005

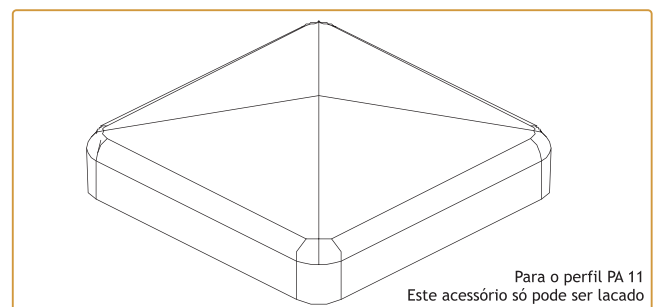

207006

TAMPA GER-008

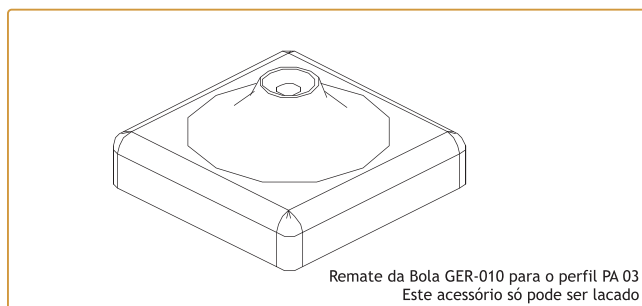

207205

REMATE PARA BOLA GER-009

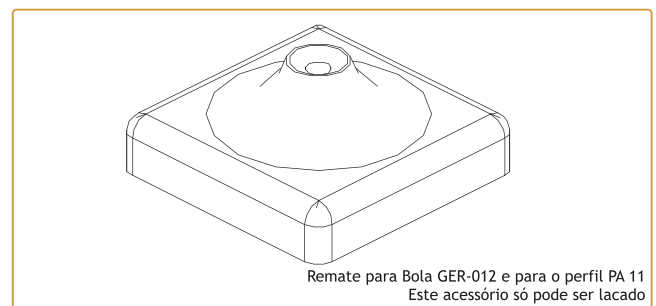

207206

REMATE PARA BOLA GER-011

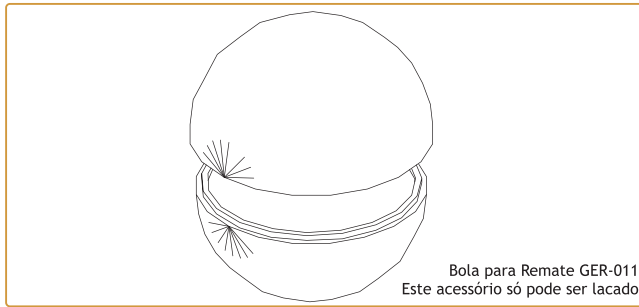

Bola para Remate GER-011
Este acessório só pode ser lacado

207082

BOLA 100 GER-012

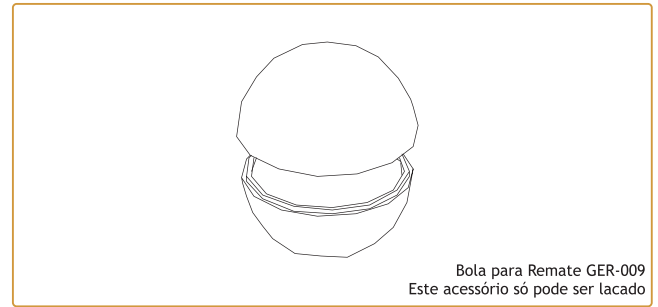

Bola para Remate GER-009
Este acessório só pode ser lacado

207080

BOLA 80 GER-010



Aplicar com os Parafusos Sextavados Interior M8x30

210169
210015
210013

TAPA-FUROS 13mm (Br./Pr.)
TAPA-FUROS 10mm PRETO
TAPA-FUROS 10mm BRANCO

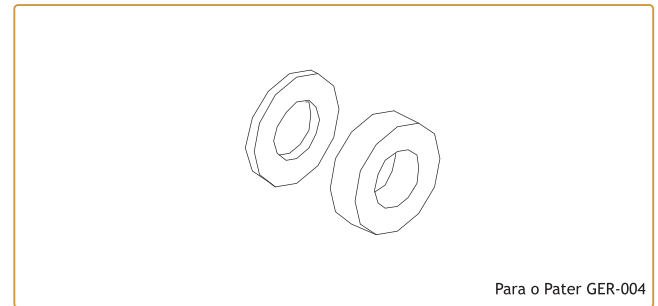

Para o Pater GER-004

217104

ANILHA COLADA AN001 INOX

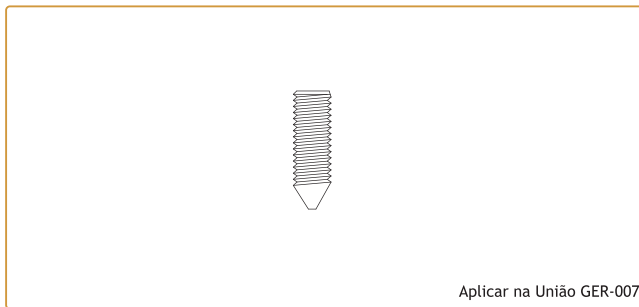

Aplicar na União GER-007

290480

PARAFUSO UMBRAKO M5x16 INOX

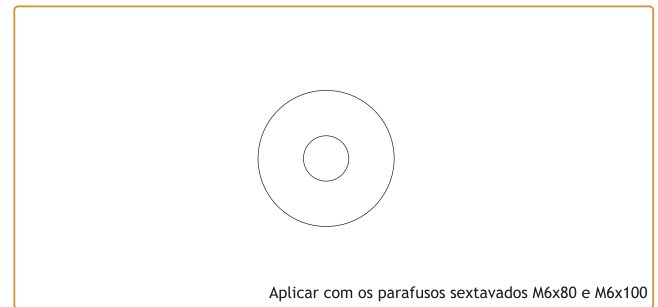

Aplicar com os parafusos sextavados M6x80 e M6x100

217114

ANILHA PLANA M6 INOX

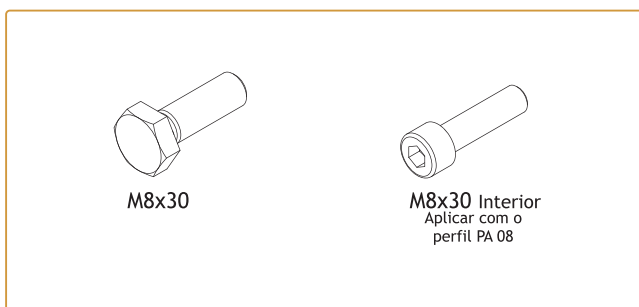

M8x30

M8x30 Interior
Aplicar com o perfil PA 08

290454
290456

PARAFUSO SEXTAVADO M8x30 INOX
PARAFUSO SEXTAVADO INTERIOR M8x30 INOX

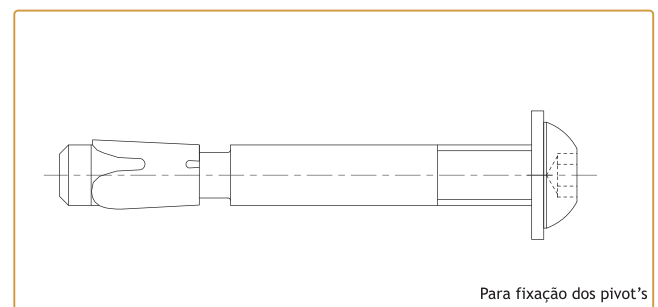

Para fixação dos pivot's

290267
290268

PARAF. M8x60 INOX A2 C/ANILHA M8 e BUCHA METÁLICA
PARAF. M10x70 INOX A2 C/ANILHA M8 e BUCHA METÁLICA

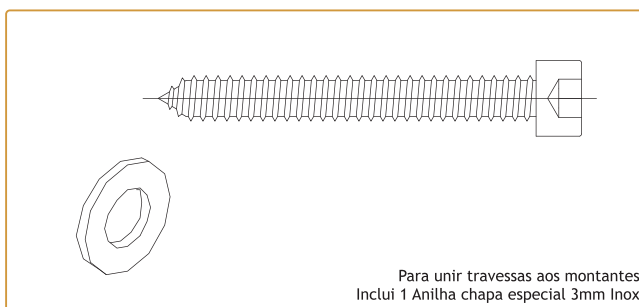

Para unir travessas aos montantes
Inclui 1 Anilha chapa especial 3mm InOX

290270

PARAFUSO 6,3x50 + ANILHA CHP ESP. 6,4x17x3 INOX A2

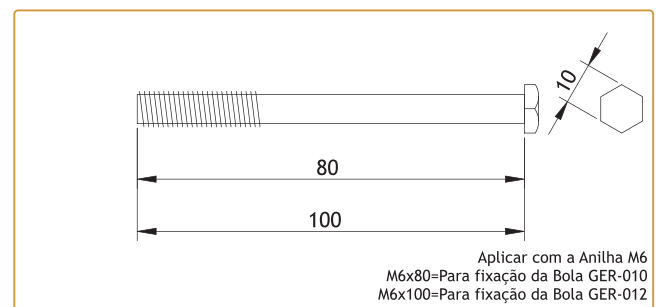

Aplicar com a Anilha M6
M6x80=Para fixação da Bola GER-010
M6x100=Para fixação da Bola GER-012

290450
290452

PARAFUSO SEXTAVADO M6x80 INOX
PARAFUSO SEXTAVADO M6x100 INOX

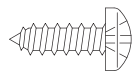

Para fixação das Lâminas PA 50

290111

PARAFUSO CQ 4,2x13 INOX A2

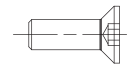

Para fixação das Tampas 3mm

210045

PARAFUSO M4x12 INOX A2

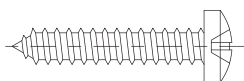

Para fixação dos Rolamentos PA

290171

PARAFUSO CQ 1x10

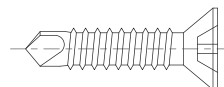

Para fixação dos Rolamentos PA

290113

PARAFUSO CX 6,3x32 INOX

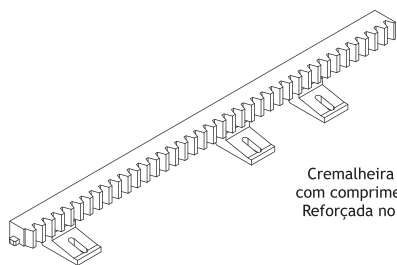

Cremalheira para automatismo,
com comprimento de 1,00m cada
Reforçada no interior com perno
10x10mm, em aço

SOB ENCOMENDA

000000

CREMALHEIRA EM POLÍMERO PRETA

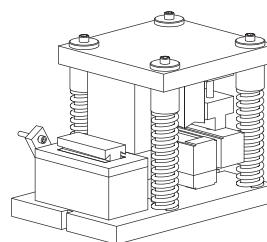

Apenas para Linha Reta

408055

CORTANTE PA+



Para aplicação nos seguintes produtos:

Topo GER-001
Topo GER-002
Topo GER-003
Topo GER-005
Topo GER-006
Topo GER-008
Topo GER-009
Topo GER-011
Topo GER-015
Topo GER-016
Topo PA 05
Topo PA 06

208001

MASTIQUE-COLA REMAFLEX 521



Junta de vedação elástica, resistente aos UV
Impede a corrosão de penetrar pelas zonas cortadas

208019

SELA JUNTAS 150gr. (Cinza)



Limpeza de alumínio lacado ou anodizado
Para preparação das zonas a serem unidas e limpeza final

208704

PRODUTO DE LIMPEZA DE ALUMÍNIO (1L) Transparente



NORTALU[®]

PORMENORES TÉCNICOS

PORTÃO DE BATENTE DE 1 e 2 FOLHAS C/ PIVOT'S LINHA RETA - COM LÂMINAS PT.250

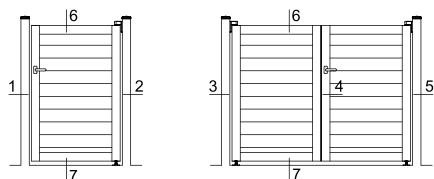

PERFIS - PORTÃO BATENTE 1 FOLHA					
REF ^A	DESIGNAÇÃO	CORTE HOR.	CORTE VERT.	QUANT	CORTE
PT.231	MONTANTE	-	H	2	
PT.238	ARO FIXO BATENTE	-	H+35	1	
PT.251	TAMPA	-	H	3	
PT.252	BATENTE LATERAL	-	H	1	
PT.234	TRAVESSA INF/SUP	L-116	-	2	
PT.250	LÂMINA	L-272	-	Variável	
PT.233	TRAV. CENTRAL (Op.)	L-116	-	1	
B.34	REFORÇO (Opcional)	L-116	-	1	
AT.30	TAMPA (ARO FIXO)	-	H+35	1	
PT.211	PRUMO (Opcional)	-	Opcional	2	

PERFIS - PORTÃO BATENTE 2 FOLHAS					
REF ^A	DESIGNAÇÃO	CORTE HOR.	CORTE VERT.	QUANT	CORTE
PT.231	MONTANTE	-	H	4	
PT.237	PERFIL BATENTE	-	H	1	
PT.251	TAMPA	-	H	5	
PT.252	BATENTE LATERAL	-	H	2	
PT.234	TRAVESSA INF/SUP	(L/2)-77	-	4	
PT.250	LÂMINA	(L/2)-233	-	Variável	
PT.233	TRAV. CENTRAL (Op.)	(L/2)-77	-	2	
B.34	REFORÇO (Opcional)	(L/2)-77	-	2	
AT.30	TAMPA (ARO MÓVEL)	-	H	1	
PT.211	PRUMO (Opcional)	-	Opcional	2	

ACESSÓRIOS			
CÓDIGO	DESIGNAÇÃO	QUANTIDADE	
		1 FOLHA	2 FOLHAS
200747	PUXADOR DUPLO 874.31	1	1
227301	QUADRA AÇO 8mm	1	1
201134	FECHADURA PRUMO PA T40	1	1
280220	TESTA PARA FECHADURA PRUMO 2000	1	1
230006	SEGREDO 30/30	1	1
201025	FECHO INF. INOX P/ 2 FOLHAS PA 16011	-	1
227119	PIVOT SUP/INF Nº.1 INOX	1*	2*
227121	PIVOT INFERIOR Nº.1 INOX	1*	2*
210042	TOPO PIVOT SUPERIOR Nº.2 PARA PT.231	1	2
210041	TOPO PIVOT INFERIOR Nº.1 PARA PT.231	1*	2*
210039	TOPO SIMPLES PARA PT.231	2	2
210035	TOPO PARA PT.238	1	-
210034	TOPO PARA PT.237	-	2
214029	BATENTE PA Nº.1 INOX	1*	2*
206150	PATER VERTICAL GER-004	2*	2*
207005	TAMPA GER-005	2*	2*
290270	PAR. 6,3x50 Inox A2 + Anilha (Para travessas)	Variável	Variável
290267	PAR. M8x60 Inox C/AN+BUC. MET. (Para pivots)	4	8
290111	PAR. CQ 4,2x13 INOX (Para Lâmina PT.250)	Variável	Variável
290112	PAR. M4x12 Inox (Para Tampas PA)	Variável	Variável

* Opcional

VEDANTES			
CÓDIGO	DESIGNAÇÃO	QUANTIDADE	
		1 FOLHA	2 FOLHAS
208008	VD 2051	1H	1H
208222	VD 2120	1H	2H
208221	VD 1033	8H	16H

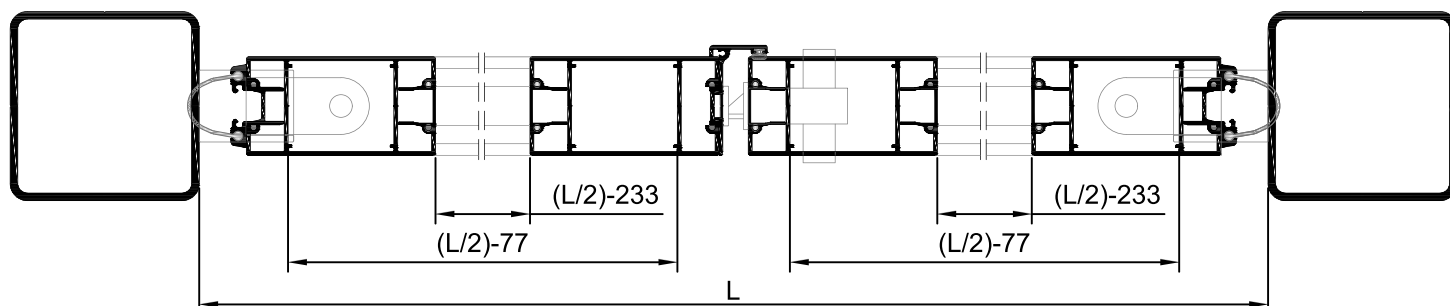
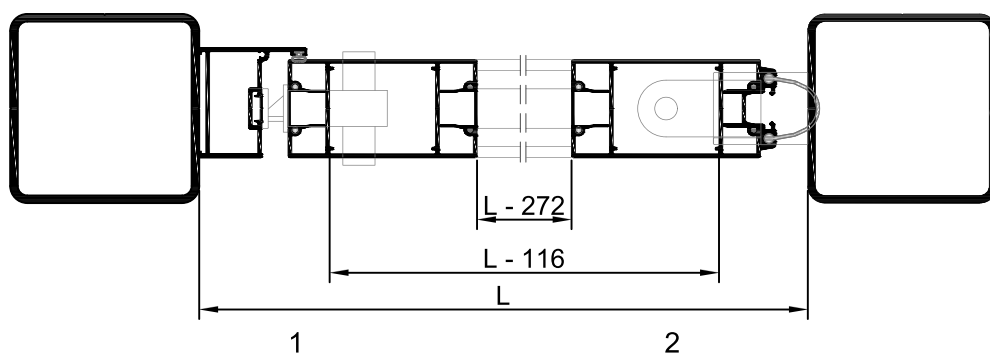
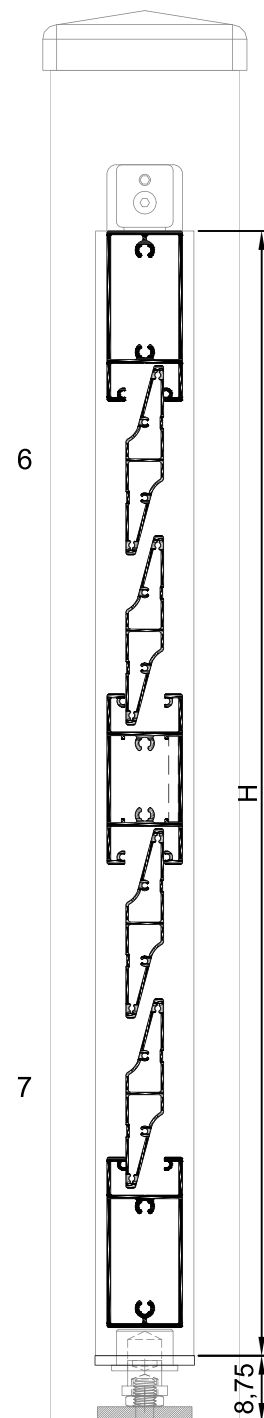

PORTÃO DE BATENTE DE 1 e 2 FOLHAS - COM DOBRADIÇAS MECHANICA LINHA RETA - COM LÂMINAS PT.250

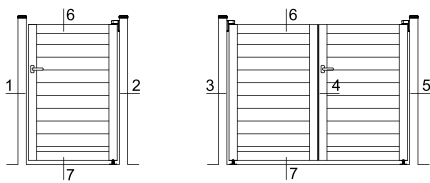

PERFIS - PORTÃO BATENTE 1 FOLHA					
REF*	DESIGNAÇÃO	CORTE HOR.	CORTE VERT.	QUANT	CORTE
PT.231	MONTANTE	-	H	2	
PT.238	ARO FIXO BATENTE	-	H+X	2	
PT.251	TAMPA	-	H	3	
PT.237	PERFIL BATENTE	-	H	1	
PT.234	TRAVESSA INF/SUP	L-136	-	2	
PT.250	LÂMINA	L-292	-	Variável	
PT.233	TRAV. CENTRAL (Op.)	L-136	-	1	
B.34	REFORÇO (Opcional)	L-136	-	1	
AT 30	TAMPA (ARO FIXO)	-	H+X	2	
AT 30	TAMPA (ARO MÓVEL)	-	H	1	

PERFIS - PORTÃO BATENTE 2 FOLHAS					
REF*	DESIGNAÇÃO	CORTE HOR.	CORTE VERT.	QUANT	CORTE
PT.231	MONTANTE	-	H	4	
PT.238	ARO FIXO BATENTE	-	H+X	2	
PT.237	PERFIL BATENTE	-	H	2	
PT.251	TAMPA	-	H	6	
PT.234	TRAVESSA INF/SUP	(L/2)-97	-	4	
PT.250	LÂMINA	(L/2)-253	-	Variável	
PT.233	TRAV. CENTRAL (Op.)	(L/2)-97	-	2	
B.34	REFORÇO (Opcional)	(L/2)-97	-	2	
AT 30	TAMPA (ARO FIXO)	-	H+X	2	
AT 30	TAMPA (ARO MÓVEL)	-	H	2	

ACESSÓRIOS			
CÓDIGO	DESIGNAÇÃO	QUANTIDADE	
		1 FOLHA	2 FOLHAS
200747	PUXADOR DUPLO 874.31	1	1
227301	QUADRA AÇO 8mm	1	1
201134	FECHADURA PRUMO PA T40	1	1
280220	TESTA PARA FECHADURA PRUMO 2000	1	1
230006	SEGREDO 30/30	1	1
202611	DOBRADIÇA MECHANICA 2 ABAS 1146.1/62.5	2*	4*
223100	KIT FIXAÇÃO PARA MECHANICA 1145.705	2*	4*
214029	BATENTE PA Nº.1 INOX	1*	2*
210008	TOPO PARA PT.231	2	4
210035	TOPO PARA PT.238	2	2
210034	TOPO PARA PT.237	2	4
201025	FECHO INF. INOX P/ 2 FOLHAS PA 16011	-	1
290270	PARAFUSO 6,3x50 INOX A2 + ANILHA	Variável	Variável
290111	PAR. CQ 4,2x13 INOX (Para Lâmina PT.250)	Variável	Variável
290112	PAR. M4x12 Inox (Para Tampas PA)	Variável	Variável

* Opcional

VEDANTES			
CÓDIGO	DESIGNAÇÃO	QUANTIDADE	
		1 FOLHA	2 FOLHAS
208008	VD 2051	3H	4H
208221	VD 1033	8H	16H

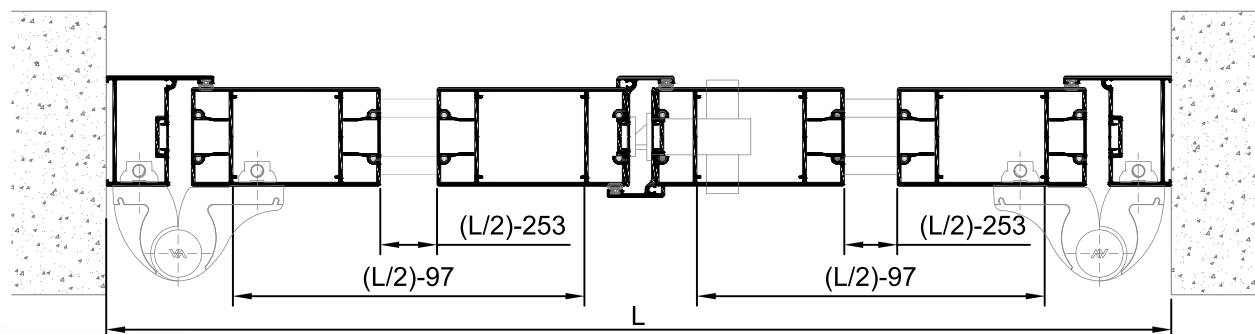
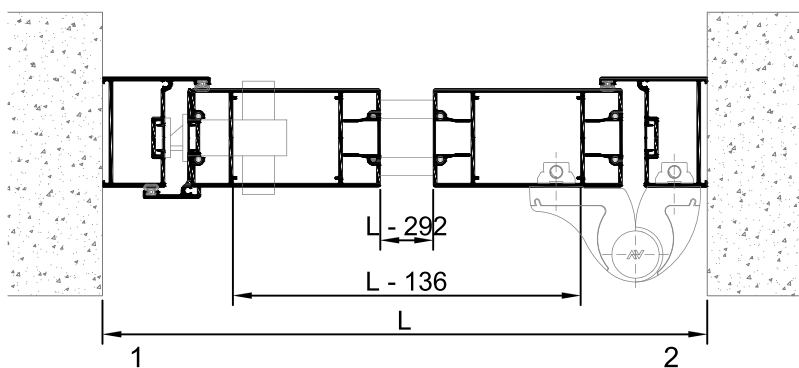
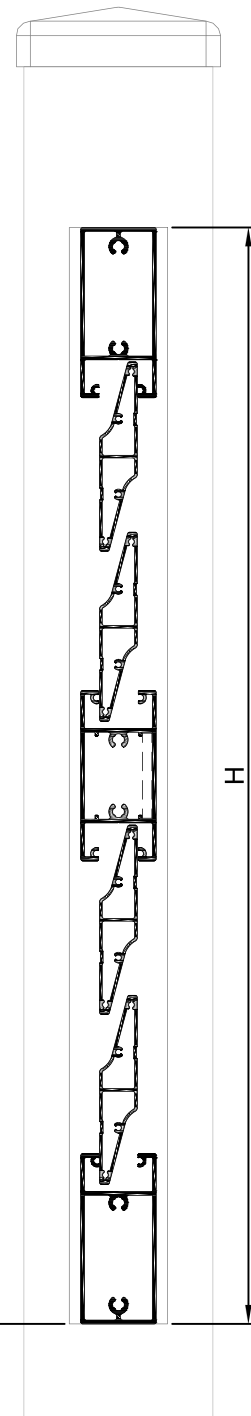

PORTÃO DE BATENTE DE 1 e 2 FOLHAS - COM DOBRADIÇA 100Kg - 180° LINHA RETA - COM LÂMINAS PT.250

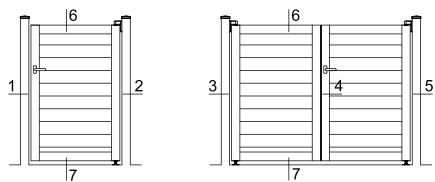

PERFIS - PORTÃO BATENTE 1 FOLHA					
REF ^a	DESIGNAÇÃO	CORTE HOR.	CORTE VERT.	QUANT	CORTE
PT.231	MONTANTE	-	H	2	
PT.251	TAMPA	-	H	4	
PT.237	PERFIL PAREDE	-	H+X	2	
PT.234	TRAVESSA INF/SUP	L-83	-	2	
PT.250	LÂMINA	L-239	-	Variável	
PT.233	TRAV. CENTRAL (Op.)	L-83	-	1	
B.34	REFORÇO (Opcional)	L-83	-	1	
AT 30	TAMPA (ARO FIXO)	-	H+X	2	

PERFIS - PORTÃO BATENTE 2 FOLHAS					
REF ^a	DESIGNAÇÃO	CORTE HOR.	CORTE VERT.	QUANT	CORTE
PT.231	MONTANTE	-	H	4	
PT.237	ARO FIXO BATENTE	-	H+X	2	
PT.237	PERFIL BATENTE	-	H	2	
PT.251	TAMPA	-	H	6	
PT.234	TRAVESSA INF/SUP	(L/2)-70	-	4	
PT.250	LÂMINA	(L/2)-226	-	Variável	
PT.233	TRAV. CENTRAL (Op.)	(L/2)-70	-	2	
B.34	REFORÇO (Opcional)	(L/2)-70	-	2	
AT 30	TAMPA (ARO FIXO)	-	H+X	2	
AT 30	TAMPA (ARO MÓVEL)	-	H	2	

ACESSÓRIOS			
CÓDIGO	DESIGNAÇÃO	QUANTIDADE	
		1 FOLHA	2 FOLHAS
200747	PUXADOR DUPLO 874	1	1
227301	QUADRA AÇO 8mm	1	1
201134	FECHADURA PRUMO PA T40	1	1
280220	TESTA PARA FECHADURA PRUMO 2000	1	1
230006	SEGREDO 30/30	1	1
202010	DOBRADIÇA INOX 100Kg	2	4
214029	BATENTE PA Nº.1 INOX	1*	2*
210008	TOPO PARA PT.231	4	4
210034	TOPO PARA PT.237	-	4
210049	TOPO PARA PT.237B	2	2
201025	FECHO INF. INOX P/ 2 FOLHAS PA 16011	-	1
290270	PARAFUSO 6,3x50 INOX A2 + ANILHA	Variável	Variável
290111	PAR. CQ 4,2x13 INOX (Para Lâmina PT.250)	Variável	Variável
290112	PAR. M4x12 Inox (Para Tampas PT)	Variável	Variável

* Opcional

VEDANTES			
CÓDIGO	DESIGNAÇÃO	QUANTIDADE	
		1 FOLHA	2 FOLHAS
208008	VD 2051	2H	4H
208221	VD 1033	8H	16H

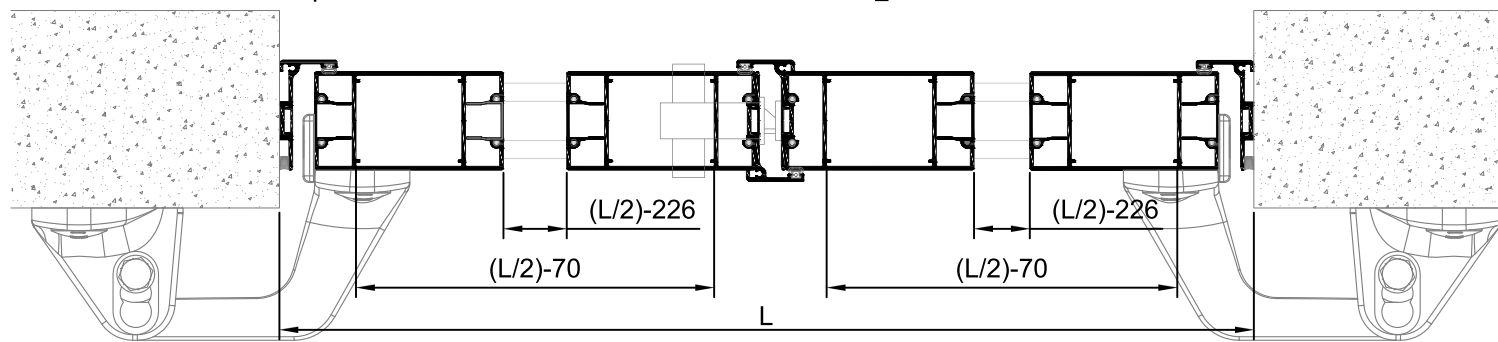
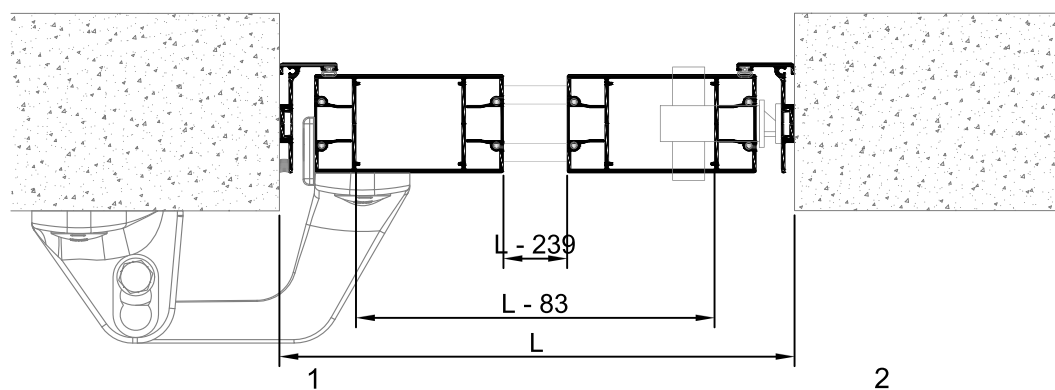
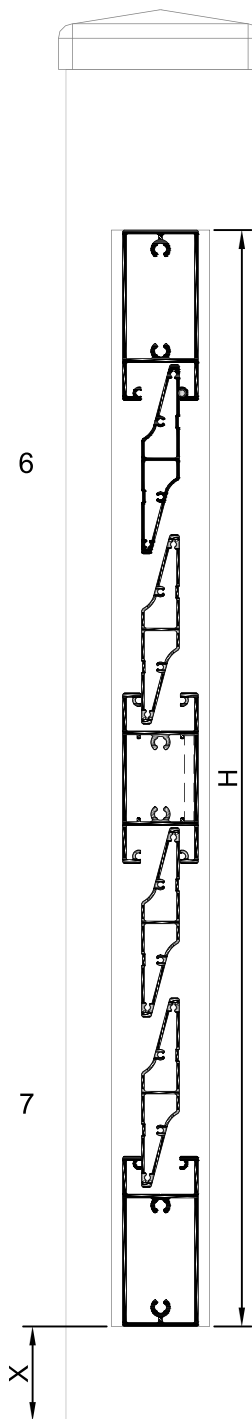

PORTÃO DE CORRER COM GUIA PT.265 LINHA RETA

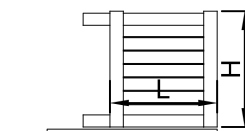

PERFIS - PORTÃO CORRER COM LÂMINA PA 50					
REFª	DESIGNAÇÃO	CORTE HOR.	CORTE VERT.	QUANT	CORTE
PT.231	MONTANTE	-	H	2	
PT.266	ARO FIXO BATENTE	-	H+28	1	
PT.267	TAMPA	-	H+28	2	
PT.251	TAMPA	-	H	4	
PT.234	TRAVESSA INF/SUP	LP+178	-	2	
PT.250	LÂMINA	LP-200	-	Variável	
PT.233	TRAV. CENTRAL (Op.)	LP-44	-	1	
PT.265	GUIA SUP CORRER	LP+97	-	1	
PT.264	GUIA SUP CORRER	LP+97	-	1	

PERFIS - PORTÃO CORRER COM LÂMINA KW 92 ou KW 82					
REFª	DESIGNAÇÃO	CORTE HOR.	CORTE VERT.	QUANT	CORTE
PT.231	MONTANTE	-	H	2	
PT.266	ARO FIXO BATENTE	-	H+28	1	
PT.267	TAMPA	-	H+28	2	
PT.251	TAMPA	-	H	2	
PT.234	TRAVESSA INF/SUP	LP+178	-	2	
W.31 ou W.36	LÂMINA	LP-160	-	Variável	
PT.233	TRAV. CENTRAL (Op.)	LP-44	-	1	
PT.265	GUIA SUP CORRER	LP+97	-	1	
PT.264	GUIA SUP CORRER	LP+97	-	1	

ACESSÓRIOS		
CÓDIGO	DESIGNAÇÃO	QUANTIDADE
200747	PUXADOR DUPLO 874.31	1*
227301	QUADRA AÇO 8mm	1*
201614	FECHADURA PRUMO 11552	1*
280243	TESTA PARA FECHADURA E06121101	1*
230006	SEGREDO 30/30 CHAV NIQUELADO	1*
207136	GUIA INOX PA 20049 (3m)	Lx2
232009	UNIÃO PARA GUIA INOX 20052	1**
207280	ROLAMENTO PA Nº.3 INOX	2*
223053	KIT GUIAS DE CORRER INOX	1*
214029	BATENTE PA Nº.1 INOX	1*
210008	TOPO PARA PT.231	4
210009	TOPO PARA PT.234	2
210038	TOPO PARA PT.266	1
210037	TOPO PARA PT.265	2
290270	PAR. 6,3x50 Inox A2 + ANILHA (Para travessas)	Variável
290267	PAR. M8x60 Inox C/AN+BUC. MET.(Para guias)	3
290111	PAR. CQ 4,2x13 INOX (Para Lâmina PT.250)	Variável
290112	PAR. M4x12 Inox (Para Tampas PT)	Variável
290113	PARAFUSO CX 6,3x32 INOX	4

* Opcional ** Para guias superiores a 3,00m

VEDANTES			
CÓDIGO	DESIGNAÇÃO	QUANTIDADE	
208008	VD 2051	2H	
208564	VEDANTE PELÚCIA 4,8X7	2H	
208221	VD 1033	COM PA 50	8H
		COM KW 82 ou 92	4L+8H

LINHA RETA
LÂMINAS PT.250

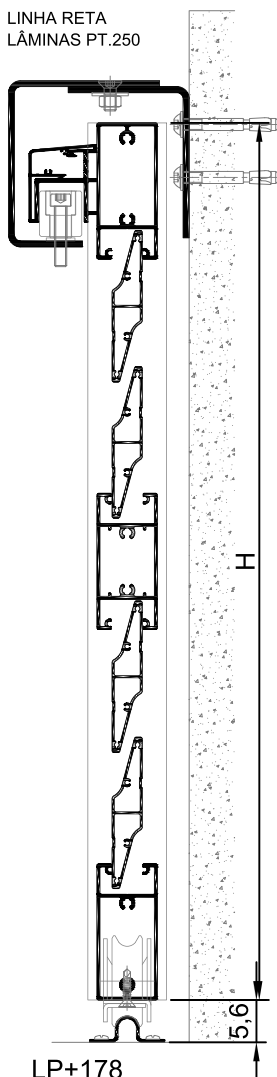

LINHA RETA
LÂMINAS W.36

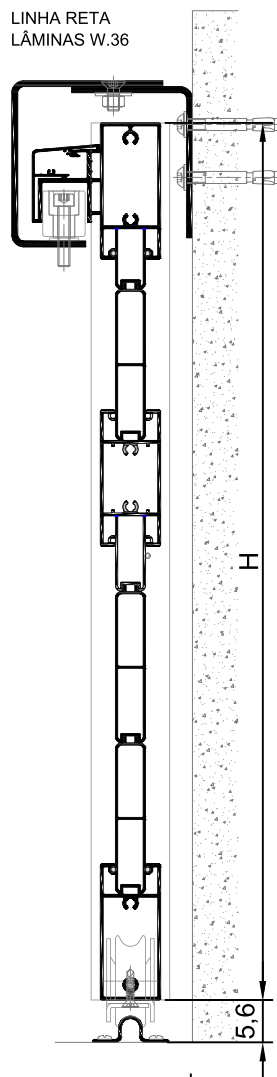

LINHA RETA
LÂMINAS W.31

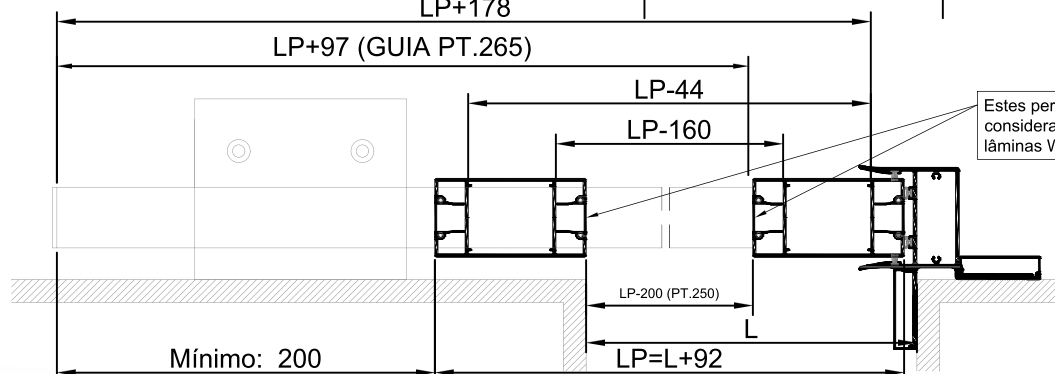
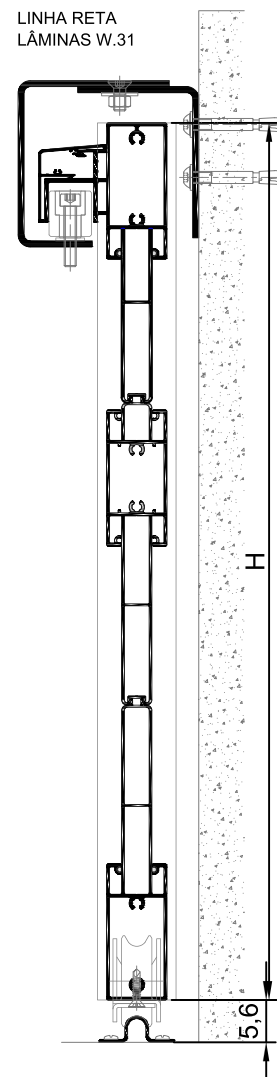

Estes perfis PT.251 não se consideram nas opções com lâminas W.36 ou W.31

PORTÃO DE CORRER COM GUIA PT.265 LINHA REDONDA

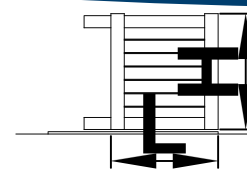

PERFIS - PORTÃO CORRER COM LÂMINA PT.250					
REF#	DESIGNAÇÃO	CORTE HOR.	CORTE VERT.	QUANT	CORTE
PT.241	MONTANTE	-	H	2	
PT.266	ARO FIXO BATENTE	-	H+28	1	
PT.267	TAMPA	-	H+28	2	
PT.251	TAMPA	LP+178	H	1 + 4	
PT.242	TRAVESSA INF/SUP	LP+178	-	2	
PT.250	LÂMINA	LP-180	-	Variável	
PT.242	TRAV. CENTRAL (Op.)	LP-44	-	1	
PT.265	GUIA SUP CORRER	LP+107	-	1	
PT.264	GUIA SUP CORRER	LP+107	-	1	

PERFIS - PORTÃO CORRER COM LÂMINA W.31 ou W.36					
REF#	DESIGNAÇÃO	CORTE HOR.	CORTE VERT.	QUANT	CORTE
PT.241	MONTANTE	-	H	2	
PT.266	ARO FIXO BATENTE	-	H+28	1	
PT.267	TAMPA	-	H+28	2	
PT.251	TAMPA	LP+178	H	1 + 2	
PT.242	TRAVESSA INF/SUP	LP+178	-	2	
W.31 ou W.36	LÂMINA	LP-140	-	Variável	
PT.242	TRAV. CENTRAL (Op.)	LP-44	-	1	
PT.265	GUIA SUP CORRER	LP+107	-	1	
PT.264	GUIA SUP CORRER	LP+107	-	1	

ACESSÓRIOS		
CÓDIGO	DESIGNAÇÃO	QUANTIDADE
200747	PUXADOR DUPLO 874.31	1*
227301	QUADRA AÇO 8mm	1*
201614	FECHADURA PRUMO 11552	1*
280243	TESTA PARA FECHADURA E06121101	1*
230006	SEGREDO 30/30 CHAV NIQUELADO	1*
207280	ROLAMENTO PA Nº.3 INOX	2*
223053	KIT GUIAS DE CORRER INOX	1*
214029	BATENTE PA Nº.1 INOX	1*
210036	TOPO PARA PT.241	4
210052	TOPO PARA PT.242	2
210038	TOPO PARA PT.266	1
210037	TOPO PARA PT.265	2
232009	UNIÃO PARA GUIA INOX 20052	1**
207136	GUIA INOX PA 20049 (3m)	Lx2
290270	PAR 6,3x50 Inox A2 + ANILHA (Para travessas)	Variável
290267	PAR. M8x60 Inox C/AN+BUC. MET.(Para guias)	3
290111	PAR. CQ 4,2x13 INOX (Para Lâmina PT.250)	Variável
290112	PAR. M4x12 Inox (Para Tampas PT)	Variável
290113	PARAFUSO CX 6,3x32 INOX	4

* Opcional ** Para guias superiores a 3,00m

VEDANTES			
CÓDIGO	DESIGNAÇÃO	QUANTIDADE	
208008	VD 2051	2H	
208564	VEDANTE PELÚCIA 4,8X7	2H	
208221	VD 1033	COM PA 50	8H
		COM KW 82 ou 92	6L+8H

LINHA REDONDA
LÂMINAS PT.250

LINHA REDONDA
LÂMINAS W.36

LINHA REDONDA
LÂMINAS W.31

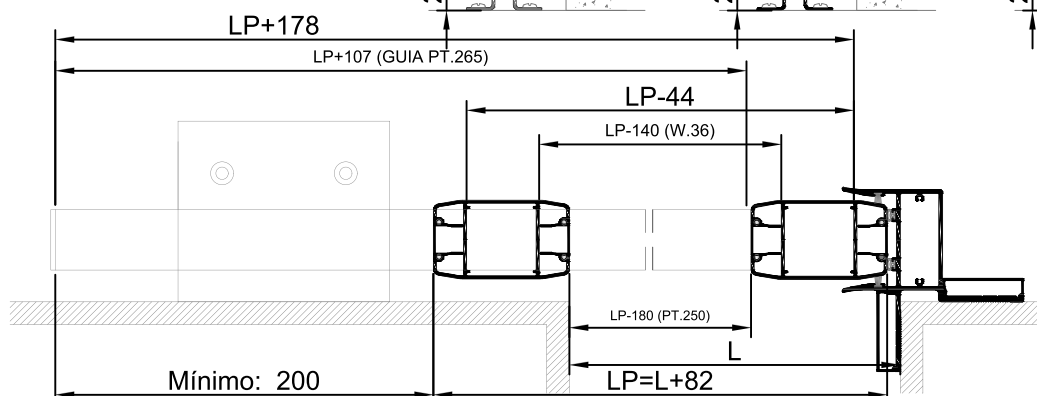
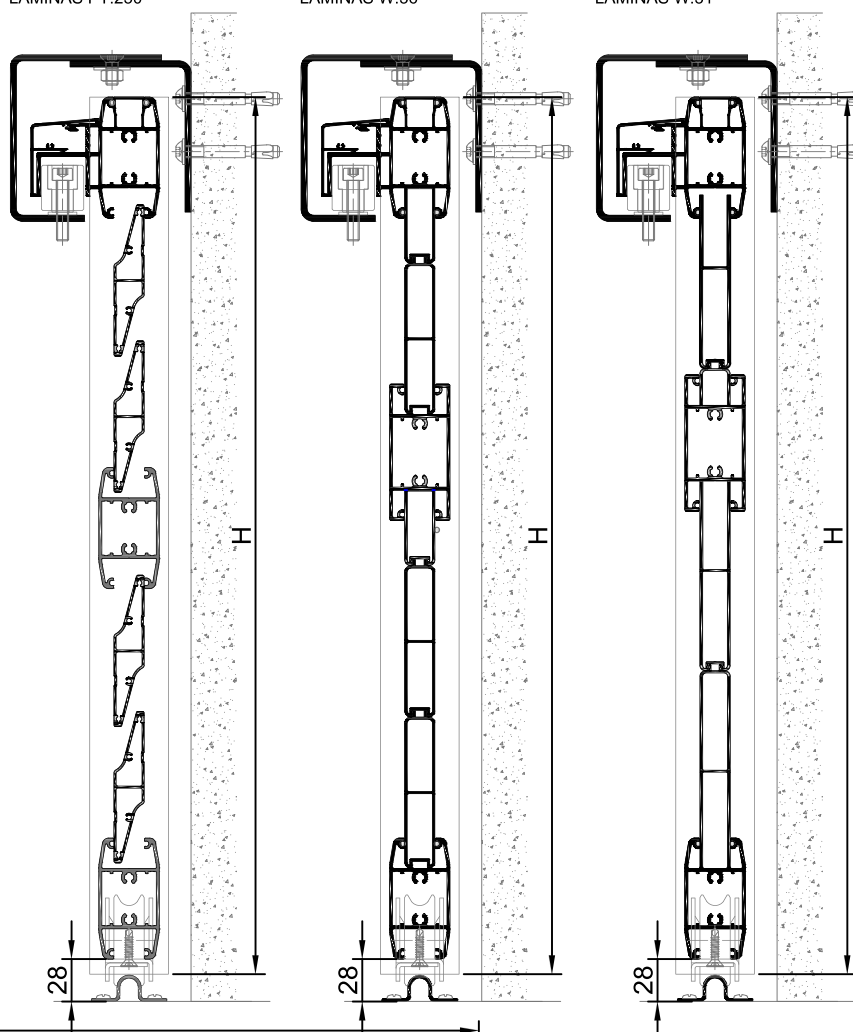



NORTALU[®]

📍 Rua Dr. José Bragança Tavares, 78 Fr. A
4580-593 Paredes(Mouriz)

☎ 255 781 548/49

☎ 92 705 80 65

✉ nortalu@nortalu.com



www.nortalu.pt



www.nortalu.com



www.nortalu.fr